



Teledyne Analytical Instruments

212R



Trace Thermal Conductivity Analyzer

The Model 212R is the most sensitive process thermal conductivity analyzer commercially available. While it is designed to detect a specific impurity in a binary gas mixture, it is also well suited for monitoring one component in more complex mixtures where the other gases have the same ratio to each other or have very similar thermal conductivity coefficients.

SENSOR THEORY OF OPERATION

The 212R uses a proven, heated 4-filament thermal conductivity detector (TCD) to effectively differentiate between the component of interest and the high purity sample gas. The detection method is an alternating current thermal conductivity cell with two flow paths – one for a known reference and another for the sample. On each side of the cell are extremely sensitive resistive filaments on opposite legs of the bridge circuit.

The high gain system makes discernible any unbalanced condition of the bridge caused by a difference in the thermal conductivity of the two similar gases with unlike amounts of impurities. The signal generated by the TCD, which is proportional to the component of interest, is in turn amplified and delivered to the user's control system or recorder to monitor the process on a continuous basis. A PID controller is used to tightly control the temperature of the detector compartment to ensure stable performance over the entire operating temperature range.

The TCD and the analyzer electronics are collectively mounted within a flush panel mount enclosure. The hinged front panel of the 212R allows easy access to the internals of the analyzer without having to remove the unit from its mounting surface. The user-friendly design also allows easy access to the sample selector calibration valve and flow control from the front. A large LED display (3.5 digits) provides easy verification of the analyzer performance from a distance. The 212R comes standard with a door, fitted with a viewing window, to prevent tampering of the controls under normal operating conditions.

The thermal conductivity detector used in the 212R is also flexible in terms of the binary applications that the detector can be utilized in. Namely:

- 0-25 ppm H₂ in Ar
- 0-25 ppm H₂ in N₂ or O₂
- 0-100 ppm N₂ in Ar
- 0-100 ppm He in Air
- 0-150 ppm N₂ in H₂ or CO
- 0-150 ppm N₂ in He
- 0-200 ppm Ar in O₂ (O₂ purity)

Flexibility, ease-of-use, high sensitivity, and competitive pricing make the Model 212R the analyzer of choice across a broad range of industries and applications.

FEATURES & BENEFITS

- Proven, highly sensitive, simple-to-use TCD
- Improved temperature control via PID
- Easy access to analyzer controls
- Stainless steel sample system
- Triple Range Capability with Range ID contacts
- Large LED readout
- Helium leak detector-tight stainless steel sample system
- 3-way valve for sample, span, and zero gas selection
- Independent indication and control for sample, reference, and bypass flows
- 9-pin test port for fine tune adjustment and diagnostic testing (without opening unit)
- Cost effective alternative to complicated gas chromatographs and ion-mobility analyzers (radioactive tritium used in the detector) which leads to safety, transportation and disposal concerns

MODEL 212R TRACE THERMAL CONDUCTIVITY ANALYZER

Applications

- Air separation plants
- H₂ purification plants
- He purification plants
- Synthetic gas plants
- Specialty chemical plants
- R&D labs

Specifications

- Ranges: Application dependent; standard with triple range capability
Contact factory to verify application feasibility
- Range ID: 3 range ID contacts (dry contact closure)
Local range ID LED's also provided on the front panel
- Outputs: Voltage – user selectable 0-1 VDC or 0-5 VDC
Current – 4-20 mADC isolated
- Detector: (4) filament thermal conductivity detector (TCD)
- Operating temperature: 20 to 35°C
- Electrical: 110V or 220 VAC, 50/60 Hz (user specified) – 500 watts maximum
- Display: Digital LED readout (3.5 digits)
- Mounting: Flush panel mount (see dimensions)
- Accuracy: ±2% full scale for most binary mixtures
- Response time: 90% full scale response in less than 60 seconds for most applications
- Stability: Less than 2% full scale drift over 24 hours
- Sample / Calibration gas flow:
- Sample: 0.3 scfh*
 - Zero & Span: 0.3 scfh*
 - Reference: 0.1 scfh*

*Typical flowrates. May change slightly depending on application.

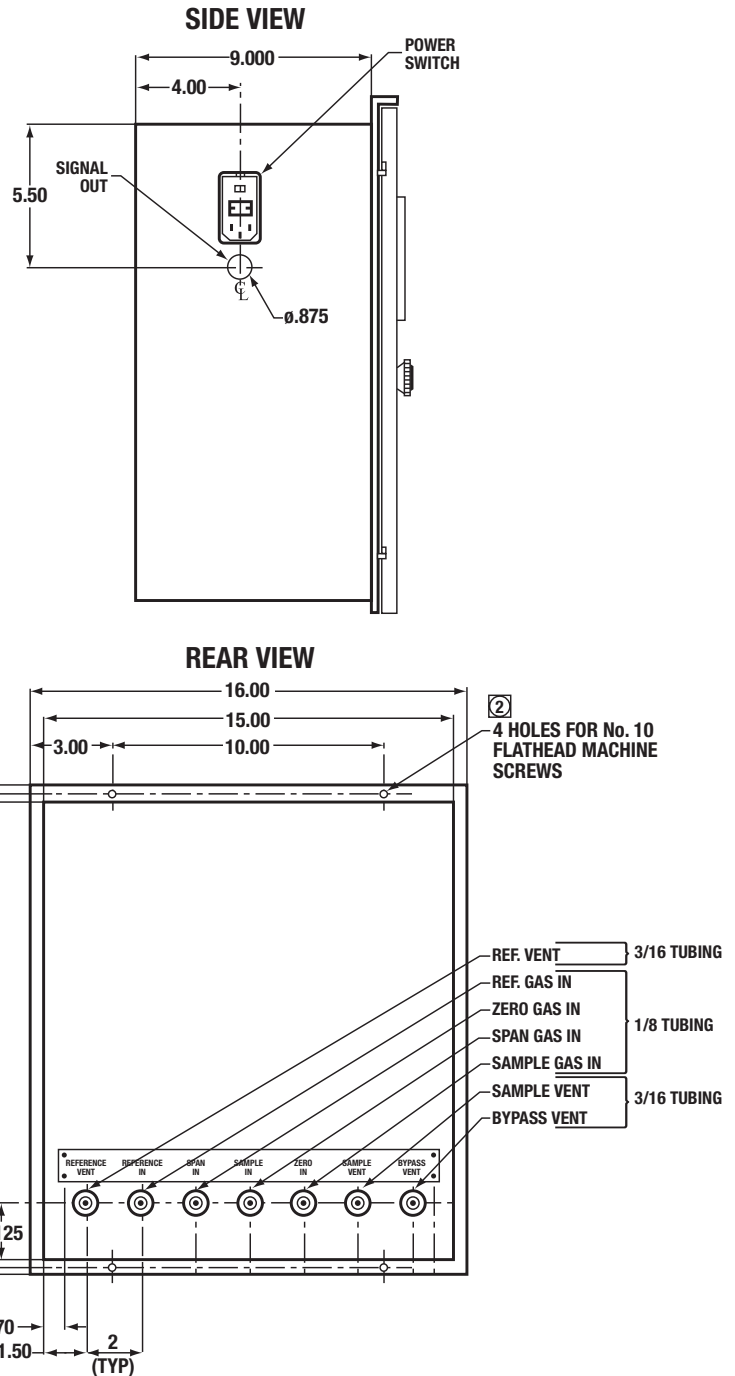

TELEDYNE ANALYTICAL INSTRUMENTS

A Teledyne Technologies Company

16830 Chestnut Street
City of Industry, California 91748, USA

TEL: 626-934-1500 FAX: 626-934-1651

TOLL FREE: 888-789-8168

Visit Our Web Site at:
www.teledyne-ai.com

Regional Office

Tokyo, Japan81-33-239-9090

© 2001 Teledyne Analytical Instruments, A Teledyne Technologies Company.
All rights reserved. Printed in the USA. 7/01LD

Warranty

Instrument is warranted for 1 year against defects in material or workmanship

NOTE: Specifications and features will vary with application. The above are established and validated during design, but are not to be construed as test criteria for every product. All specifications and features are subject to change without notice.

