

NOTES: UNLESS OTHERWISE SPECIFIED.

1. CONNECTION FOR SENSING ELECTRODE.
2. CONNECTION FOR COUNTER ELECTRODE.
3. CONNECTION FOR REFERENCE ELECTRODE.

REVISIONS				
REV.	DESCRIPTION	DATE	APP.	REV.
0	REL. ECO# 96-578	9-17-96	M.G.	--

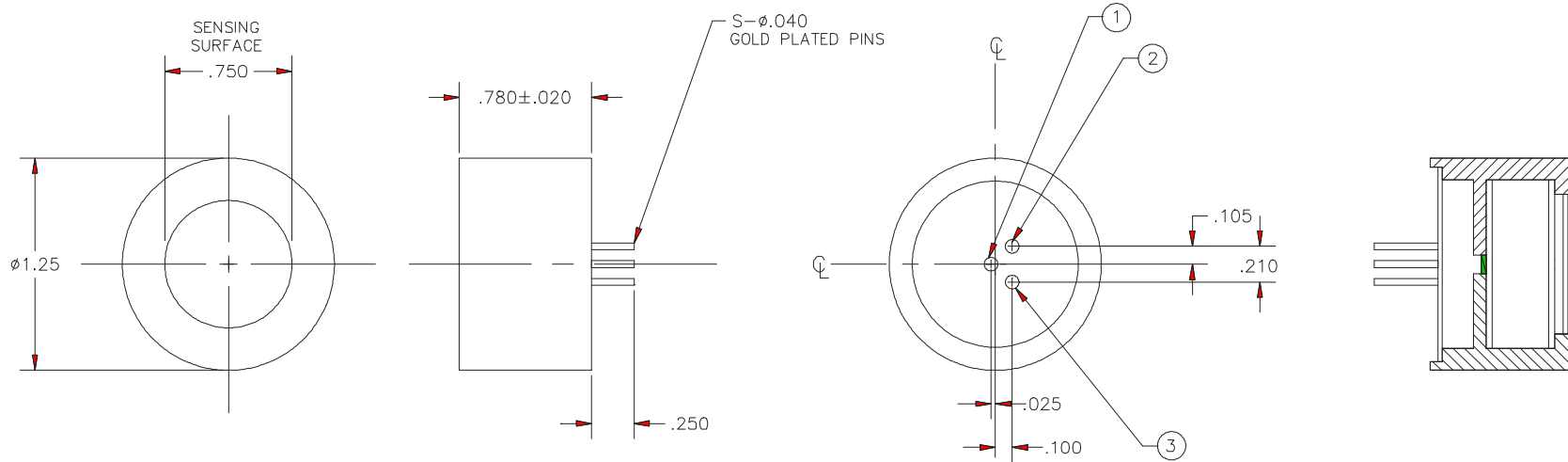

SPECIFICATION

OUTPUT IN AIR - +0.00 TO +15.00 MICROAMPS AT 25 DEG. C, SEA LEVEL
OUTPUT CO IN AIR - +0.332 TO +1.042 MICROAMPS PER PPM AT 25 DEG. C, SEA LEVEL
RANGE- 0 - 500 PPM CARBON MONOXIDE IN AIR
RESPONSE TIME - LESS THAN 30 SECONDS FOR 90% OF STEP CHANGE IN CO CONCENTRATION.
RECOVERY TIME - LESS THAN 60 SECONDS FOR 90% WITH AIR OR ZERO GAS EQUIVALENT.
BIAS POTENTIAL - NEGATIVE 75 MV
HUMIDITY - 5 TO 99% R.H. (NON-CONDENSING).
OPERATING TEMPERATURE RANGE - 0 TO 40 DEG. C (32 TO 104 DEG. F)
STORAGE TEMPERATURE - 0 TO 50 DEG. C (32 TO 122 DEG. F)
EXPECTED CELL LIFE - 12 MONTHS IN AIR AT 25 DEG. C AND 50% R.H.
WEIGHT - 0.4oz (12 GRAMS)
SENSOR ASSY TO BE BAGGED IN A GAS METALIZED BARRIER BAG.



ITEM	QTY	PART NO.	DESCRIPTION	
BILL OF MATERIAL				
DO NOT SCALE DWG		THIS DRAWING IS THE PROPERTY OF TELEDYNE ANALYTICAL INSTRUMENTS AND CONTAINS CONFIDENTIAL INFORMATION. IT IS NOT TO BE COPIED, REPRODUCED OR USED WITHOUT WRITTEN PERMISSION.		
TOLERANCE UNLESS OTHERWISE SPECIFIED: ANGULAR $\pm 1/2^\circ$		 Teledyne Analytical Instruments A business unit of Teledyne Electronic Technologies CITY OF INDUSTRY, CALIFORNIA 91748		
LINEAR				$\begin{matrix} X & = & \pm .1 \\ .XX & = & \pm .02 \\ .XXX & = & \pm .005 \end{matrix}$
SIGNATURES				DATE
I/	DRFT:	<i>Maritza</i>	7/17/96	
N/	CHK:			
P/	APPR:	M. GONZALEZ		
O/	ENGR:	MICHAEL GONZALEZ		
F/	S.O.			
REFERENCE	CAD ID	C66399-0		
TITLE			SCALE	
SPECIFICATION CONTROL			2:1	
CO SENSOR - CLASS F2			SIM C-57530	
TAI P/N C-33586-F2			SHEET 1 OF 1	
MATERIAL		DWG NO.	REV	
		C-66399	0	