

Portable Oxygen Analyzers

	311XL & 311TCXL	311, 311D, 311TC & 311PC	TURBO2 & TURBO2P
Ranges	0-2, 0-10, 0-100, 0-1000 ppm oxygen plus cal range for air calibration	<i>Trace:</i> 0-10, 0-100, 0-1000, 0-10,000 ppm oxygen plus cal range for air calibration (311D has a low range of 0-100 ppm) <i>Percent:</i> 0-1, 0-2.5, 0-5, 0-10% oxygen plus calibration range	0-100, 0-1000, 0-10,000 ppm oxygen plus cal range for air calibration
Sensitivity	20 ppb	0.5% of full scale	0.5% of full scale
Accuracy	±2% of full scale (±5% of range in the 0-2 ppm range) at a constant 25°C temperature and constant pressure ±5% (±10% of range in the 0-2 ppm range) over operating temperature range 0-35°C (once equilibrium has been achieved) at constant temperature	±2% of full scale (±1 ppm for 0-10 ppm range) at a constant temperature and pressure (temperature and pressure of calibration) ±5% of full scale (±1 ppm for 0-10 ppm range) over operating temperature range (once temperature equilibrium has been achieved)	±2% of full scale at constant temperature and pressure ±5% of full scale over operating temperature (once temperature equilibrium has been achieved)
Operating temperature	32 to 95°F (0 to 35°C)	32 to 122°F (0 to 50°C)	32 to 122°F (0 to 50°C)
Response time	90% in 5 to 10 seconds 90% in 60 seconds (0-10 ppm range) 90% in 90 seconds (0-2 ppm range) at 2.5 SCFH	90% in 5 to 10 seconds 90% in 60 seconds (0-10 ppm range)	90% of full scale in less than 10 seconds
Reproducibility	±1% at constant temperature	±1% at constant temperature	±1% at constant temperature
Sensor type	B-2CXL	B-2C (trace) B-1 (percent) Others available	S-2
Power requirements	AC power for battery recharge circuit of two current limited, rechargeable NiCad batteries, 100-115 Vac, 50/60 Hz (220 Vac, 50/60 Hz optional) 0.25 amps	AC power for battery recharge circuit of two current limited, rechargeable NiCad batteries, 115 Vac, 50/60 Hz (100 / 220 Vac optional) 0.25 amps	AC power for battery recharge circuit of two current limited, rechargeable NiCad batteries, 110 Vac, 60 Hz (100 / 220 Vac, 50/60 Hz optional) 0.25 amps
Weight	6 lbs. (2.71 kg)	6 lbs. (2.71 kg)	7 lbs. (3 kg)
Approvals	Factory Mutual (FM)* BASEEFA* <i>*certification pending at time of printing</i>	Standard: Intrinsically safe (Class I, Division 1, Groups A, B, C, and D) Factory Mutual (FM) approved CENELEC: BASEEFA certified for EExibIICT4 intrinsically safe for zone 1 and 2; hydrogen, ethylene, oxide; temperature class — no surface temperatures above 135°C	None

TELEDYNE ANALYTICAL INSTRUMENTS

16830 Chestnut Street
City of Industry, California 91748, USA

TEL: 626-934-1500 FAX: 626-934-1651

TOLL FREE: 888-789-8168

Visit Our Web Site at:
www.teledyne-ai.com



Warranty: Instrument is warranted for 1 year against defects in material or workmanship

NOTE: Specifications and features will vary with application. The above are established and validated during design, but are not to be construed as test criteria for every product. All specifications and features are subject to change without notice.



TELEDYNE ANALYTICAL INSTRUMENTS

311
SERIES
TURBO₂



Portable Oxygen Analysis • Versatile and Rugged

PORTABLE OXYGEN ANALYZERS

Analysis of oxygen has become a part of every industry that uses or produces gas or gas mixtures. Teledyne's complete line of portable gas analyzers provides this vital analysis in a compact package operating without an external power source. Oxygen concentration in the sample gas stream is measured by Teledyne's own advanced Micro-fuel Cell sensor specific to oxygen. The high-accuracy and fast response of these units is ideal for measuring oxygen in hydrogen, nitrogen, argon, helium, acetylene, ethylene, butadiene, carbon dioxide, and many other gases.

Teledyne's complete line of portables features instruments for both trace and percent analysis in as low as the 0-2 ppm range. Digital and analog meters are available, as are a number of additional options to assure a match to individual applications. CENELEC, BASEEFA and Factory Mutual approval units are also offered.

MAINTENANCE FREE SENSOR

Teledyne's sensors set industry standards for accuracy, sensitivity, and ease of use. And because every sensor undergoes stringent testing and quality control, the end user is assured of outstanding reliability and performance. These patented Micro-fuel Cells are sealed, electrochemical devices with no electrolyte to change or electrodes to clean, making them virtually maintenance free. The sensors are specific to oxygen and are capable of accurately monitoring gas streams containing up to 100% hydrocarbons.

EASY CALIBRATION

The 311 and TURBO₂ families have a special cal range that allows accurate calibration with the most economical, reliable, abundant standardization gas there is -- atmospheric air. No special span gas is required, and because the sensors offer an absolute zero, there is never a need for a zero gas.

PRINCIPLE OF ANALYSIS

Oxygen in the sample diffuses into the Micro-fuel Cell and reacts chemically to produce an electrical signal that is linearly proportional to the oxygen concentration in the sample gas. This electrochemical reaction is specific to oxygen and is unaffected by the presence of oxidizable gases (carbon monoxide, methane, hydrogen, etc.). The signal produced by the Micro-fuel Cell is electronically amplified and displayed on an analog or digital meter readout.

LONG LIFE, RECHARGEABLE BATTERIES

The low operating power required by these units is supplied by two internally mounted, nickel cadmium batteries. Fully charged, these batteries supply enough capacity to operate the unit for approximately 30 days. An overnight charge once a month keeps these batteries in service for many years. An integral charging circuit and detachable power cord allow convenient charging.

Model	Analysis	Meter	Certification
311XL	Trace	Analog	FM*
311TCXL	Trace	Analog	BASEEFA*
311	Trace	Analog	FM
311D	Trace	Digital	None
311TC	Trace	Analog	CENELEC / BASEEFA
311PC	Percent	Analog	CENELEC / BASEEFA
TURBO ₂	Trace	Analog	None
TURBO ₂ P	Trace	Analog	None

**certification pending at time of printing*

APPLICATIONS

- Air separation and liquefaction
- Pure gaseous hydrocarbon stream monitoring
- Semiconductor manufacturing
- Protective atmosphere blanketing of primary liquid feedstocks and flammable liquids
- Process analysis of gaseous monomers – vinyl chloride, propylene, butadiene, isoprene, or ethylene
- Gas purity certification
- Glove box or pipeline leak detection
- Natural gas treatment and transmission
- Catalyst protection
- Inert gas welding of exotic metals
- Wave and reflow soldering
- Heat treating and bright annealing
- Nuclear fuel processing and isotope separation
- Analysis of chemical reactions
- Headspace gas analysis
- SF6 circuit breakers
- Crystal growth
- Plastics manufacturing

OPTIONS

- 100 or 220 Vac operation
- Stainless steel quick disconnect gas fittings (female); mating set (3) of stainless-steel male fittings (vent, sample, calibration)
- Carrying case
- Special ranges
- Stainless steel cell block (311 family only)
- Integral sample pump (TURBO₂P)

FEATURES

- Three (TURBO₂) or four (311 family) linear ranges plus a calibration range
- High accuracy and sensitivity; fast response
- Unaffected by hydrocarbons and other oxidizable gases
- Ideal for measuring oxygen in hydrogen, nitrogen, argon, helium, acetylene, ethylene, butadiene, and many other gases
- Long-life, maintenance-free, Micro-fuel Cell oxygen sensor
- No support gases required
- Rugged, lightweight, and reliable

The **311XL** and **311TCXL** are portable, intrinsically safe trace oxygen analyzers which can be operated without an external power source, providing analysis in decade steps ranging from 0-2 to 0-10,000 ppm full scale plus a special calibration range encompassing the known oxygen concentration of atmospheric air. The 311TCXL version is BASEEFA certified.*

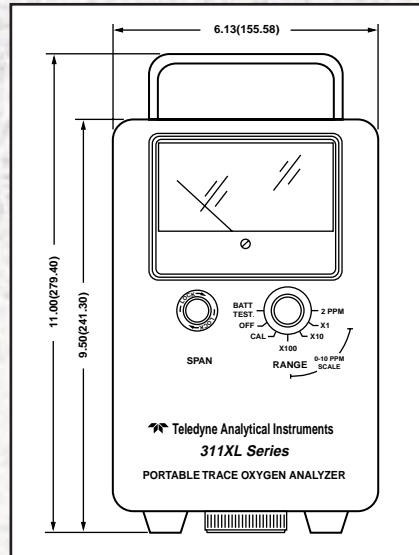

Measurements are given in inches and millimeters. The instrument is 5 - 5/8" (142.8mm) deep.

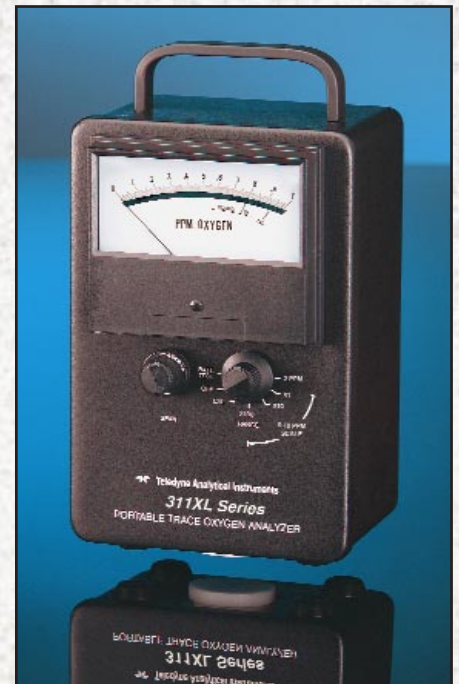

The 311XL Series analyzes O₂ in as low as the 0-2 ppm range.

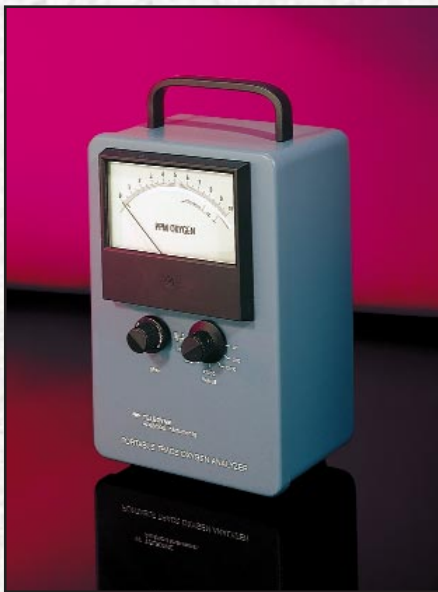

The 311 Series of trace and percent analyzers offers many configurations.

The **311** series provides complete oxygen analysis in a compact package. Offering high accuracy and fast response, this unit is available in four different configurations. The 311 is the basic trace, battery powered unit. The 311D adds a digital meter for easy viewing and readout accuracy. The 311TC and 311PC are trace and percent units which have received CENELEC approval.

The **TURBO₂** and **TURBO₂P** are portable trace oxygen analyzers that do not need an external power source to operate and can be reliably calibrated without the use of calibration gases. The instrument provides for analysis in the 0-100, 0-1000 and 0-10,000 ppm ranges full scale plus a calibration range. Sample flow control, although not critical (0.1 to 10 liters / min) is either accomplished with accessory equipment or by the addition of an optional pump and flowmeter (TURBO₂P).

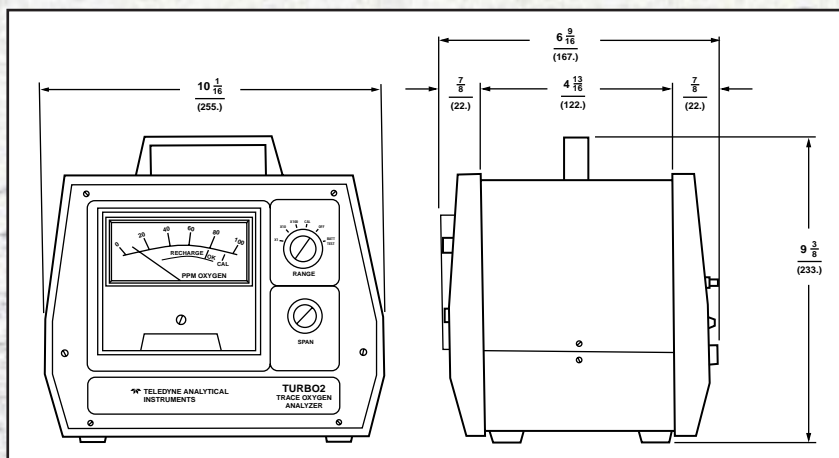

Measurements are given in inches and millimeters.

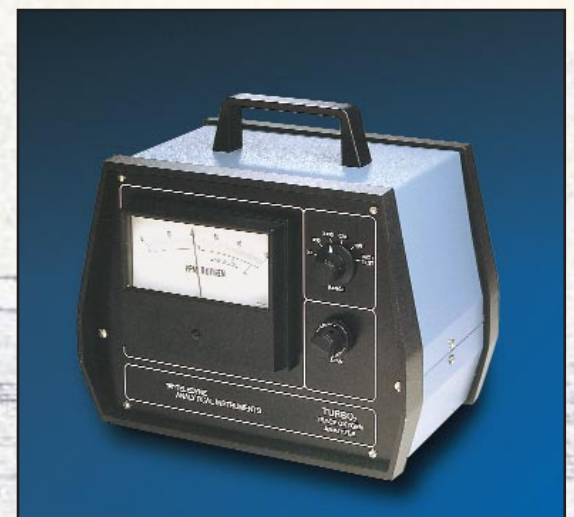

The TURBO₂ Series offers low cost, analog, trace O₂ analysis.