OPERATING INSTRUCTIONS FOR

Model 2000A-EU

Thermal Conductivity Analyzer



DANGER



HIGHLY TOXIC AND OR FLAMMABLE LIQUIDS OR GASES MAY BE PRESENT IN THIS MONITORING SYSTEM.

PERSONAL PROTECTIVE EQUIPMENT MAY BE REQUIRED WHEN SERVICING THIS SYSTEM.

HAZARDOUS VOLTAGES EXIST ON CERTAIN COMPONENTS INTERNALLY WHICH MAY PERSIST FOR A TIME EVEN AFTER THE POWER IS TURNED OFF AND DISCONNECTED.

ONLY AUTHORIZED PERSONNEL SHOULD CONDUCT MAINTENANCE AND/OR SERVICING. BEFORE CONDUCTING ANY MAINTENANCE OR SERVICING CONSULT WITH AUTHORIZED SUPERVISOR/MANAGER.

P/N M66182
08/06/99
ECO # 99-0323

Copyright © 1999 Teledyne Analytical Instruments

All Rights Reserved. No part of this manual may be reproduced, transmitted, transcribed, stored in a retrieval system, or translated into any other language or computer language in whole or in part, in any form or by any means, whether it be electronic, mechanical, magnetic, optical, manual, or otherwise, without the prior written consent of Teledyne Analytical Instruments, 16830 Chestnut Street, City of Industry, CA 91749-1580.

Warranty

This equipment is sold subject to the mutual agreement that it is warranted by us free from defects of material and of construction, and that our liability shall be limited to replacing or repairing at our factory (without charge, except for transportation), or at customer plant at our option, any material or construction in which defects become apparent within one year from the date of shipment, except in cases where quotations or acknowledgements provide for a shorter period. Components manufactured by others bear the warranty of their manufacturer. This warranty does not cover defects caused by wear, accident, misuse, neglect or repairs other than those performed by Teledyne or an authorized service center. We assume no liability for direct or indirect damages of any kind and the purchaser by the acceptance of the equipment will assume all liability for any damage which may result from its use or misuse.

We reserve the right to employ any suitable material in the manufacture of our apparatus, and to make any alterations in the dimensions, shape or weight of any parts, in so far as such alterations do not adversely affect our warranty.

Important Notice

This instrument provides measurement readings to its user, and serves as a tool by which valuable data can be gathered. The information provided by the instrument may assist the user in eliminating potential hazards caused by his process; however, it is essential that all personnel involved in the use of the instrument or its interface, with the process being measured, be properly trained in the process itself, as well as all instrumentation related to it.

The safety of personnel is ultimately the responsibility of those who control process conditions. While this instrument may be able to provide early warning of imminent danger, it has no control over process conditions, and it can be misused. In particular, any alarm or control systems installed must be tested and understood, both as to how they operate and as to how they can be defeated. Any safeguards required such as locks, labels, or redundancy, must be provided by the user or specifically requested of Teledyne at the time the order is placed.

Therefore, the purchaser must be aware of the hazardous process conditions. The purchaser is responsible for the training of personnel, for providing hazard warning methods and instrumentation per the appropriate standards, and for ensuring that hazard warning devices and instrumentation are maintained and operated properly.

Teledyne Analytical Instruments, the manufacturer of this instrument, cannot accept responsibility for conditions beyond its knowledge and control. No statement expressed or implied by this document or any information disseminated by the manufacturer or its agents, is to be construed as a warranty of adequate safety control under the user's process conditions.

Specific Model Information

The instrument for which this manual was supplied may incorporate one or more options not supplied in the standard instrument. Commonly available options are listed below, with check boxes. Any that are incorporated in the instrument for which this manual is supplied are indicated by a check mark in the box.

Instrument Serial Number: _____

Options Available with Order:

- 2000A-C:** Auto Calibration valves (zero/span) built-in gas selector panel and control valves are electronically controlled to provide synchronization with the analyzer's operations.
- 2000A-G:** Stainless steel cell block with nickel filaments and Stainless Steel fittings and tubing.
- 2000A-H:** Stainless steel cell block with gold filaments for corrosive gas streams and Stainless Steel fittings and tubing.
- 2000A-K:** 19" Rack Mount available with either one or two analyzers Control Units installed and ready to mount in a standard rack
- 2000A-L:** Gas selector panel consisting of sample/ref flow meters and control valves for metering input of sample/calibrations support gases
- 2000A-R:** Sealed reference cell (application dependent, contact factory).
- 2000A-N:** 220 VAC operation.

Model 2000A-EU complies with all of the requirements of the Commonwealth of Europe (CE) for Radio Frequency Interference, Electromagnetic Interference (RFI/EMI), and Low Voltage Directive (LVD).

The following International Symbols are used throughout the Instruction Manual for your visual and immediate warnings and when you have to attend CAUTION while operating the instrument:



STAND-BY, Instrument is on Stand-by, but circuit is active



GROUND
Protective Earth



CAUTION, The operator needs to refer to the manual for further information. Failure to do so may compromise the safe operation of the equipment.



CAUTION, Risk of Electric Shock



This is a general purpose instrument designed for usage in a nonhazardous area. It is the customer's responsibility to ensure safety especially when combustible gases are being analyzed since the potential of gas leaks always exist.

The customer should ensure that the principles of operating of this equipment is well understood by the user. Misuse of this product in any manner, tampering with its components, or unauthorized substitution of any component may adversely affect the safety of this instrument.

Since the use of this instrument is beyond the control of Teledyne, no responsibility by Teledyne, its affiliates, and agents for damage or injury from misuse or neglect of this equipment is implied or assumed.

Table of Contents

1 Introduction

1.1 Overview 1-1
1.2 Typical Applications 1-2
1.3 Main Features of the Analyzer 1-2
1.4 Model Designations 1-3
1.5 Front Panel (Operator Interface) 1-3
1.6 Recognizing Difference Between LCD & VFD 1-5
1.7 Rear Panel (Equipment Interface) 1-5
1.8 Gas Connections 1-7

2 Operational Theory

2.1 Introduction 2-1
2.2 Sensor Theory 2-1
 2.2.1 Sensor Configuration 2-1
 2.2.2 Calibration 2-2
 2.2.3 Effects of Flowrate and Gas Density 2-3
 2.2.4 Measurement Results 2-3
2.3 Electronics and Signal Processing 2-3
2.4 Temperature Control 2-5

3 Installation

3.1 Unpacking the Analyzer 3-1
3.2 Mounting the Analyzer 3-1
3.3 Electrical Connections (Rear Panel) 3-3
 3.3.1 Primary Input Power 3-4
 3.3.2 Primary Input Power 3-4
 3.3.3 50-Pin Equipment Interface Connector 3-4
 3.3.3.1 Analog Outputs 3-5
 3.3.3.2 Alarm Relays 3-6
 3.3.3.3 Digital Remote Cal Inputs 3-7
 3.3.3.4 Range ID Relays 3-9
 3.3.3.5 Network I/O 3-9
 3.3.3.6 Remote Valve Connector 3-9
 3.3.4 RS-232 Port 3-10
3.4 Gas Connections 3-11
 3.4.1 Sample System Design 3-13
 3.4.2 Pressure and Flow Rate Regulation 3-13
 3.4.3 VENT Exhaust 3-14
 3.4.4 SAMPLE Gas 3-14

3.4.5	REFERENCE Gas	3-15
3.4.6	ZERO Gas	3-15
3.4.7	SPAN Gas	3-15
3.5	Testing the System	3-16
3.6	Warm Up at Power Up	3-16

4 Operation

4.1	Introduction	4-1
4.2	Using the Data Entry and Function Buttons	4-1
4.3	The <i>System</i> Function	4-4
4.3.1	Setting the Display	4-5
4.3.2	Setting up an Auto-Cal	4-5
4.3.3	Password Protection	4-6
4.3.3.1	Entering the Password	4-7
4.3.3.2	Installing or Changing the Password	4-7
4.3.4	Logging Out	4-9
4.3.5	System Self-Diagnostic Test	4-9
4.3.6	The Model Screen	4-10
4.3.7	Checking Linearity with ALGORITHM	4-10
4.4	The <i>Zero</i> and <i>Span</i> Functions	4-11
4.4.1	Zero Cal	4-12
4.4.1.1	Auto Mode Zeroing	4-12
4.4.1.2	Manual Mode Zeroing	4-13
4.4.1.3	Cell Failure	4-14
4.4.2	Span Cal	4-14
4.4.2.1	Auto Mode Spanning	4-15
4.4.2.2	Manual Mode Spanning	4-15
4.5	The <i>Alarms</i> Function	4-16
4.6	The <i>Range</i> Function	4-18
4.6.1	Manual (Select/Define Range) Screen	4-19
4.6.2	Auto (Single Application) Screen	4-19
4.6.3	Precautions	4-21
4.7	The <i>Analyze</i> Function	4-22
4.8	Programming	4-22
4.8.1	The Set Range Screen	4-23
4.8.2	The Curve Algorithm Screen	4-25
4.8.2.1	Checking the Linearization	4-25
4.8.2.2	Manual Mode Linearization	4-26
4.8.2.3	Auto Mode Linearization	4-27
4.9	Special Function Setup	4-28
4.9.1	Output Signal Reversal	4-28

4.9.2	Special - Inverting Output	4-29
4.9.3	Special - Polarity Coding.....	4-29
4.9.4	Special - Nonlinear Application Gain Preset	4-29

Maintenance

5.1	Routine Maintenance	5-1
5.2	System Self Diagnostic Test.....	5-1
5.3	VFD Display	5-2
5.4	Fuse Replacement	5-2
5.5	Major Internal Components	5-3
5.6	Cell, Heater, and/or Thermistor Replacement	5-5
5.6.1	Removing the Cell Compartment.....	5-5
5.6.2	Removing and Replacing the Cell Block	5-6
5.6.3	Removing the Heater and/or Thermocouple	5-7
5.7	Cleaning	5-4
5.8	Phone Numbers	5-5

Appendix

A-1	Specifications	A-1
A-2	Recommended 2-Year Spare Parts List	A-3
A-3	Drawing List	A-4
A-4	19-Inch Relay Rack Panel Mount.....	A-4



Introduction

1.1 Overview

The Analytical Instruments Model 2000 Thermal Conductivity Analyzer is a versatile microprocessor-based instrument for measuring a component gas in a background gas, or in a specific mixture of background gases. 2000A-EU Analyzer complies with all of the requirements of the Commonwealth of Europe (CE) for Radio Frequency Interference and Electromagnetic Interference (RFI/EMI) protection. It compares the thermal conductivity of a sample stream with that of a reference gas of known composition. The 2000 can—

- measure the concentration of one gas in a mixture of two gases.
- measure the concentration of a gas in a specific mixture of background gases.
- measure the purity of a sample stream containing a single impurity or a mixture of impurities.

The standard 2000 is preprogrammed with automatic linearization algorithms for a large number of gases and gas mixtures. The factory can add to this data base for custom applications, or the sophisticated user can add his own unique application.

This manual covers the Model 2000A-EU General Purpose flush-panel and rack-mount units only. **These units are for indoor use in a nonhazardous environment.**

Many of the Model 2000 features covered in this manual are optional, selected according to the customer's specific application. Therefore, the user will find much here that does not apply to his instrument. This is unavoidable due to the number of possible combinations of features available. We have endeavored to make the manual as usable and convenient as possible, in light of this flexibility.

1.2 Typical Applications

A few typical applications of the Model 2000 are:

- Power Generation
- Air liquefaction
- Chemical reaction monitoring
- Steel manufacturing and heat treating
- Petrochemical process control
- Quality assurance
- Refrigeration and storage
- Gas proportioning control.

1.3 Main Features of the Analyzer

The main features of the Model 2000 Thermal Conductivity Analyzer include:

- Three independent, user definable, analysis ranges allow up to three different gas applications with one concentration range each, or up to three concentration ranges for a single gas application, or any combination.
- Special recalibration range for multiple applications. Recalibrating one, recalibrates all.
- Automatic, independent linearization for each range.
- Auto Ranging allows analyzer to automatically select the proper preset range for a given single application. Manual override allows the user to lock onto a specific range of interest.
- RS-232 serial digital port for use with a computer or other digital communications device.
- Two adjustable concentration alarms and a system failure alarm.
- Extensive self-diagnostic testing, at startup and on demand.
- A 2-line alphanumeric display screen, driven by microprocessor electronics, that continuously prompts and informs the operator.
- High resolution, accurate indication of target or impurity gas concentration from large, bright, meter readout. (0-9999 ppm through 0-100 % depending on types of gas involved.)
- Standard, proven sensor cell design.
- Wide range of custom applications, ranges, and linearization.

- Microprocessor based electronics: 8-bit CMOS microprocessor with 32 kB RAM and 128 kB ROM.
- Auto and remote calibration capabilities.
- CE Mark Certified.
- Four analog outputs: two for measurement (0–1 V dc and Isolated 4–20 mA dc) and two for range identification.
- Compact and versatile design: Small footprint, yet internal components are accessible.

1.4 Model Designations

The Model 2000A-EU is ordinarily custom programmed at the factory to fit the customer's application. Many parameters, including the number of channels, the gas application, the materials specification of the sampling system, and others, are options. The most common options, are covered in this manual. See the *Specific Model Information* checklist in the front pages of this manual for those that apply to your Model 2000A analyzer. Some standard models that are not covered in this manual are listed here.

Models 2000B: NEMA-4, bulkhead mounted enclosure for general purpose, nonhazardous environments.

Models 2010: Split architecture models using a sealed explosion-proof enclosure for the Analysis Unit and a general purpose remote Control Unit for installation in a safe area.

Models 2020: Both the analysis section and control unit are in a single explosion proof enclosure.

1.5 Front Panel (Operator Interface)

The 2000A is housed in a rugged metal case with all controls and displays accessible from the front panel. See Figure 1-1. The front panel has thirteen buttons for operating the analyzer, a digital meter, and an alphanumeric display. They are described briefly here and in detail in the *Operations* chapter of this manual.

Function Keys: Six touch-sensitive membrane switches are used to change the specific function performed by the analyzer:

- **Analyze** Perform analysis for target-gas content of a sample gas.

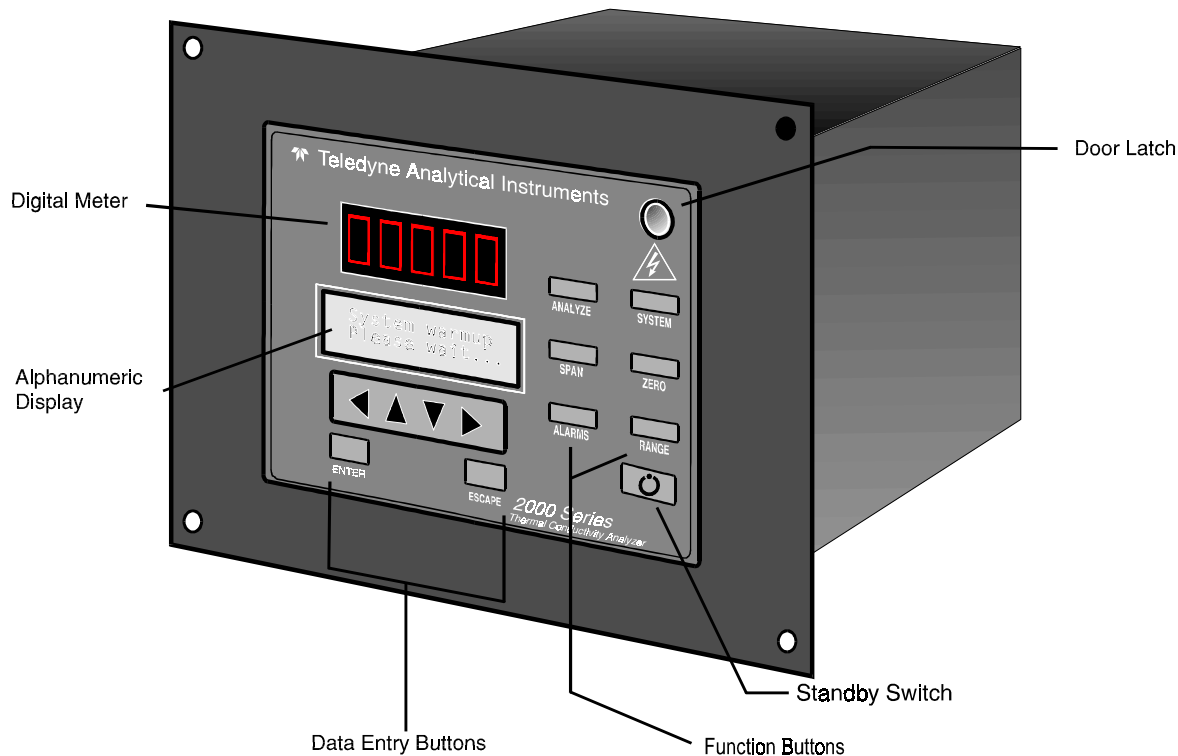

Figure 1-1: Model 2000A Front Panel

- **System** Perform system-related tasks (described in detail in chapter 4, *Operation*).
- **Span** Span calibrate the analyzer.
- **Zero** Zero calibrate the analyzer.
- **Alarms** Set the alarm setpoints and attributes.
- **Range** Set up the user definable ranges for the instrument.

Data Entry Keys: Six touch-sensitive membrane switches are used to input data to the instrument via the alphanumeric VFD display:

- **Left & Right Arrows** Select between functions currently displayed on the VFD screen.
- **Up & Down Arrows** Increment or decrement values of functions currently displayed.
- **Enter** Moves VFD on to the next screen in a series. If none remains, returns to the *Analyze* screen.

- **Escape** Moves VFD back to the previous screen in a series. If none remains, returns to the *Analyze* screen.

Digital Meter Display: The meter display is a LED device that produces large, bright, 7-segment numbers that are legible in any lighting. It produces a continuous trace readout from 0-9999 ppm or a continuous percent readout from 1-100 %. It is accurate across all analysis ranges.

Alphanumeric Interface Screen: The VFD screen is an easy-to-use interface between operator and analyzer. It displays values, options, and messages that give the operator immediate feedback.

 **Standby Button:** The Standby turns off the display and outputs, but circuitry is still operating.

CAUTION: *The power cable must be unplugged to fully disconnect power from the instrument. When chassis is exposed or when access door is open and power cable is connected, use extra care to avoid contact with live electrical circuits.*

Access Door: For access to the thermal conductivity sensor or the front panel electronics, the front panel swings open when the latch in the upper right corner of the panel is pressed all the way in with a narrow gauge tool. Accessing the main electronics circuit board requires unfastening rear panel screws and sliding the electronics drawer out of the case. (See chapter 5.)

CAUTION: *The Access door must be closed and latched for CE mark compliance to be in effect.*

1.6 Recognizing Difference Between LCD & VFD

LCD has *GREEN* background with *BLACK* characters. VFD has *DARK* background with *GREEN* characters. In the case of VFD - *NO CONTRAST ADJUSTMENT IS NEEDED.*

1.7 Rear Panel (Equipment Interface)

All electrical inputs and outputs to the 2000A are made through rear-panel connectors. The connectors are described briefly here and in detail in chapter 3, *Installation.*

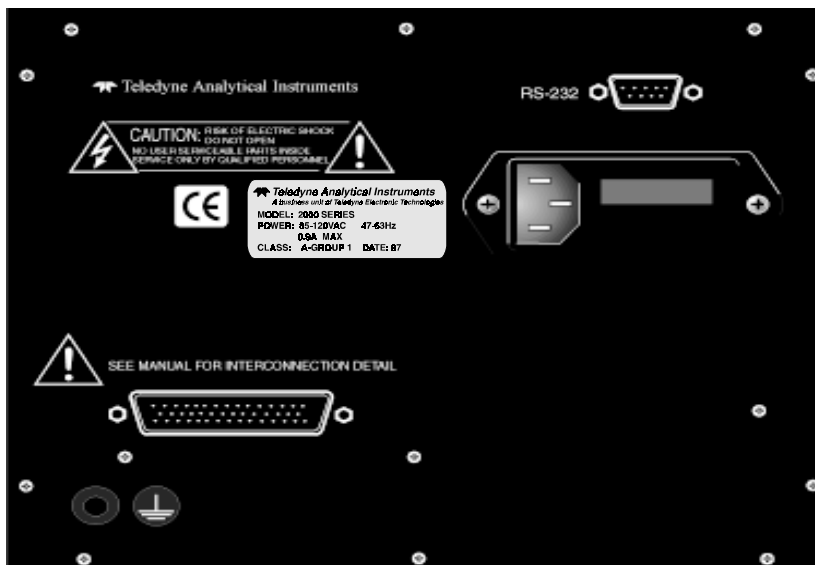

Figure 1-2: Model 2000A-EU Rear Panel

- **Power Connection** Universal AC power source.
- **9-Pin RS-232 Port** Serial digital concentration signal output and control input.
- **50-Pin Equipment Interface Port**
 - **Analog Outputs** 0-1 V dc concentration plus 0-1 V dc range ID, and isolated 4-20 mA dc plus 4-20 mA dc range ID.
 - **Alarm Connections** 2 concentration alarms and 1 system alarm.
 - **Remote Valve** Used in the 2000 for controlling external solenoid valves only.
 - **Remote Span/Zero** Digital inputs allow external control of analyzer calibration.
 - **Calibration Contact** To notify external equipment that instrument is being calibrated and readings are not monitoring sample.
 - **Range ID Contacts** Four separate, dedicated, range-identification relay contacts (00, 01, 02, 03).

Note: If you require highly accurate Auto-Cal timing, use external Auto-Cal control where possible. The internal clock in the Model 2000 is accurate to 2-3 %. Accordingly, internally scheduled calibrations can vary 2-3 % per day.

1.8 Gas Connections

The gas connectors are on the bottom of the Model 2000A chassis near the front panel. There are no gas control valves inside the main chassis. Electronic input/output ports are provided on the rear panel for the operation of solenoid valves under the complete control of the Model 2000 electronics. See section 3.3.

A sample system must be provided for introduction of zero and span gas, as well as sample gas, into the sample path, and for controlling the flowrates through the sample and reference paths of the analyzer. Appropriate pressure reducing regulators must be installed at all gas supply sources.

Gas Connector-and-Control Panels for specific applications are available as extra cost additions. These panels are usually designed around a standard manifold that attaches to the Model 2000 series analyzer below the front panel.

For those customers wishing to incorporate their own sample controls, the recommended system piping schematic is included among the drawings at the rear of the manual.

Operational Theory

2.1 Introduction

The analyzer is composed of two subsystems:

1. Thermal Conductivity Sensor
2. Electronic Signal Processing, Display and Control.

The sensor is a thermal conductivity comparator that continuously compares the thermal conductivity of the sample gas with that of a reference gas having a known conductivity.

The electronic signal processing, display and control subsystem simplifies operation of the analyzer and accurately processes the sampled data. A microprocessor controls all signal processing, input/output, and display functions for the analyzer.

2.2 Sensor Theory

For greater clarity, Figure 2-1 presents two different illustrations, (a) and (b), of the operating principle of the thermal conductivity cell.

2.2.1 Sensor Configuration

The thermal conductivity sensor contains two chambers, one for the reference gas of known conductivity and one for the sample gas. Each chamber contains a pair of heated filaments. Depending on its thermal conductivity, each of the gases conducts a quantity of heat away from the filaments in its chamber. See Figure 2-1(a).

The resistance of the filaments depends on their temperature. These filaments are parts of the two legs of a Wheatstone bridge circuit that unbalances if the resistances of its two legs do not match. See Figure 2-1(b).

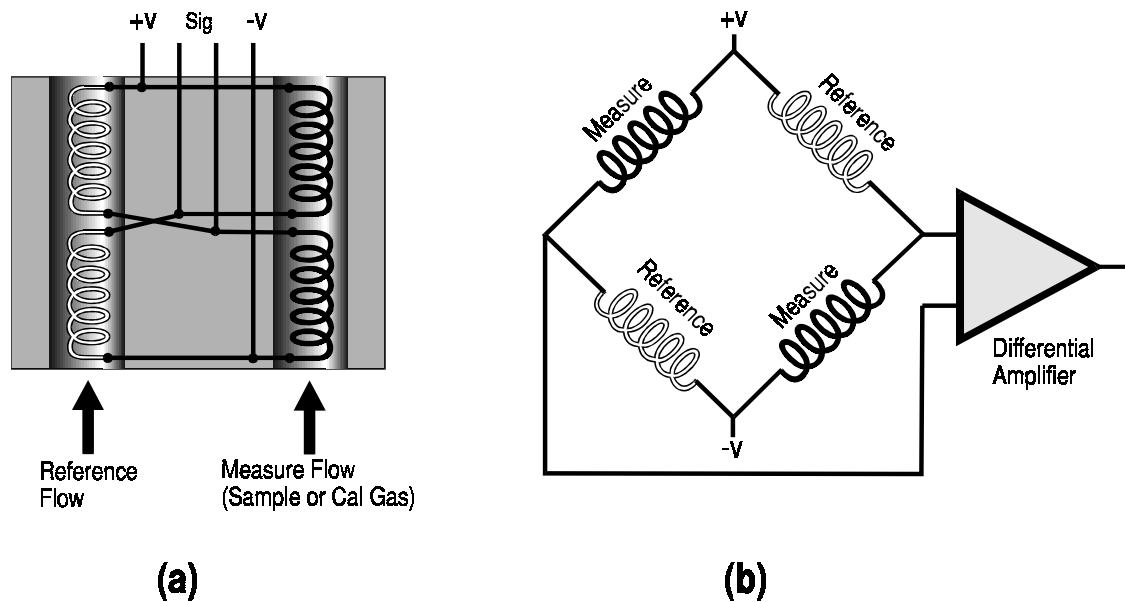

Figure 2-1: Thermal Conductivity Cell Operating Principle

If the thermal conductivities of the gases in the two chambers are different, the Wheatstone bridge circuit unbalances, causing a current to flow in its detector circuit. The amount of this current can be an indication of the amount of impurity in the sample gas, or even an indication of the type of gas, depending on the known properties of the reference and sample gases.

The temperature of the measuring cell is regulated to within 0.1 °C by a sophisticated control circuit. Temperature control is precise enough to compensate for diurnal effects in the output over the operating ranges of the analyzer. (See *Specifications* in the Appendix for details.)

2.2.2 Calibration

Because analysis by thermal conductivity is not an absolute measurement, calibration gases of **known composition** are required to fix the upper and lower parameters (“zero” and “span”) of the range, or ranges, of analysis. These gases must be used periodically, to check the **accuracy of the analyzer**.

During calibration, the bridge circuit is balanced, with zero gas against the reference gas, at one end of the measurement range; and it is sensitized with span gas against the reference gas at the other end of the measurement range. The resulting electrical signals are processed by the analyzer electronics to produce a standard 0-1 V, or an isolated 4–20 mA dc, output signal, as described in the next section.

2.2.3 Effects of Flowrate and Gas Density

Because the flowrate of the gases in the chambers affects their cooling of the heated filaments, the flowrate in the chambers must be kept as equal, constant, and low as possible.

When setting the sample and reference flowrate, note that gases lighter than air will have an actual flowrate higher than indicated on the flowmeter, while gases heavier than air will have an actual flowrate lower than indicated. Due to the wide range of gases that are measured with the Thermal Conductivity Analyzer, the densities of the gases being handled may vary considerably.

Then, there are limited applications where the reference gas is in a sealed chamber and does not flow at all. These effects must be taken in consideration by the user when setting up an analysis.

2.2.4 Measurement Results

Thermal conductivity measurements are nonspecific by nature. This fact imposes certain limitations and requirements. If the user intends to employ the analyzer to detect a specific component in a sample stream, the sample must be composed of the component of interest and one other gas (or specific, and constant, mixture of gases) in order for the measured heat-transfer differences to be nonambiguous.

If, on the other hand, the user is primarily interested in the purity of a process stream, and does not require specific identification of the impurity, the analyzer can be used on more complex mixtures.

2.3 Electronics and Signal Processing

The Model 2000 Thermal Conductivity Analyzer uses an 8031 microcontroller (Central Processing Unit—CPU) with 32 kB of RAM and 128 kB of ROM to control all signal processing, input/output, and display functions for the analyzer. System power is supplied from a universal power supply module designed to be compatible with any international power source. (See *Major Internal Components* in chapter 5 *Maintenance* for the location of the power supply and the main electronic PC boards.)

The Temperature Control board is mounted on the inner face of the rear panel, under the power input receptacle. The signal processing electronics including the microprocessor, analog to digital, and digital to analog converters are located on the Motherboard at the bottom of the case.

The Preamplifier board is mounted on top of the Motherboard as shown in the figure (in chapter 5). These boards are accessible after removing the back panel. Figure 2-2 is a block diagram of the Analyzer electronics.

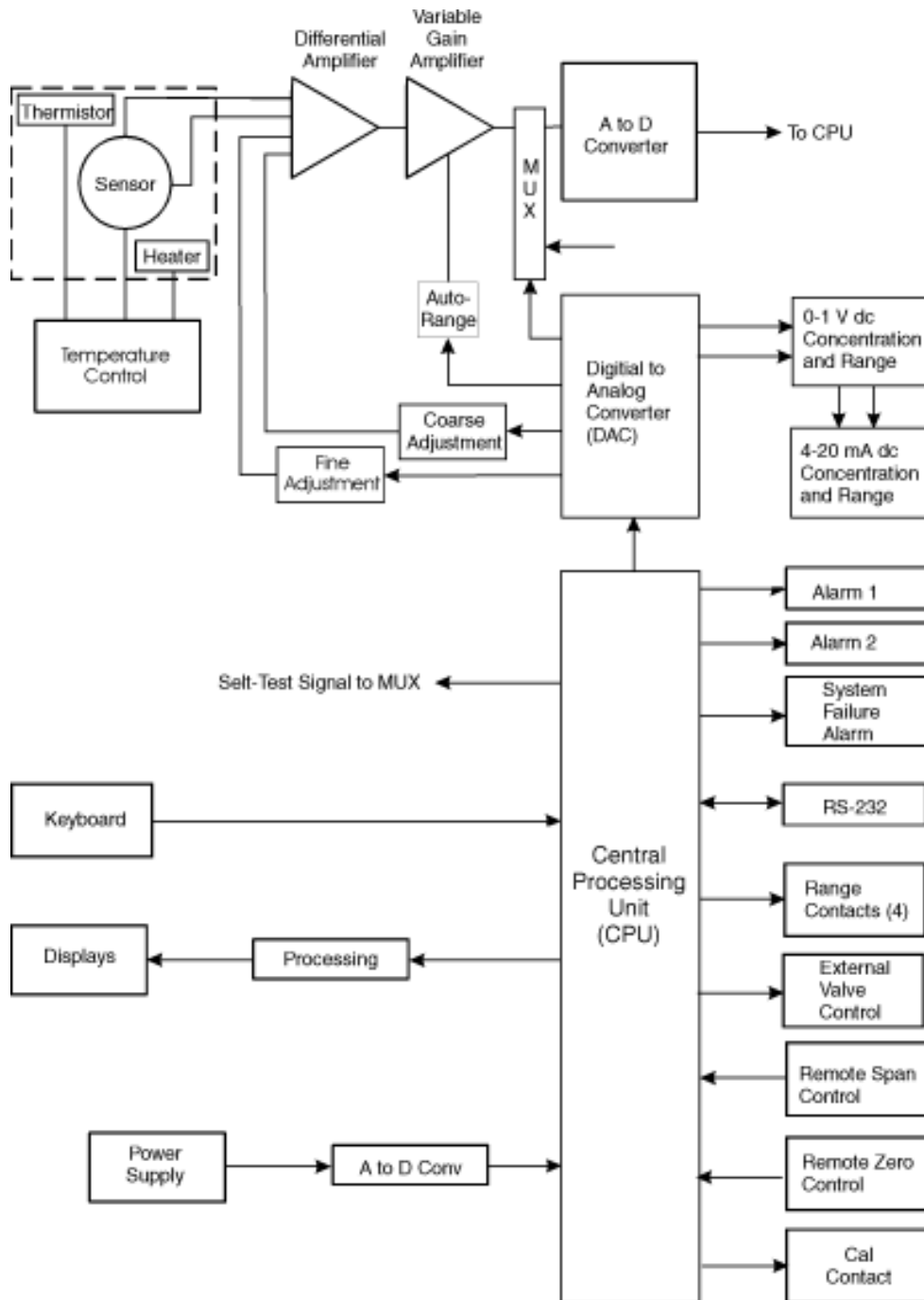

Figure 2-2: Block Diagram of the Model 2000 Electronics

The Temperature Control Board keeps the temperature of the measuring cell regulated to within 0.1 degree C. A thermistor is used to measure the temperature, and a zero-crossing switch regulates the power in a cartridge-type heater. The result is a sensor output signal that is temperature independent.

In the presence of dissimilar gases the sensor generates a differential voltage across its output terminals. A differential amplifier converts this signal to a unipolar signal, which is amplified in the second stage, variable gain amplifier, which provides automatic range switching under control of the CPU. The output from the variable gain amplifier is sent to an 18 bit analog to digital converter.

The digital concentration signal along with input from the control panel is processed by the CPU and passed on to the 12-bit DAC, which outputs 0-1 V dc Concentration and Range ID signals. An voltage-to-current converter provides 4-20 mA dc concentration signal and range ID outputs.

The CPU also provides appropriate control signals to the Displays, Alarms, and External Valve Controls, and accepts digital inputs for external Remote Zero and Remote Span commands. It monitors the power supply through an analog to digital converter as part of the data for the system failure alarm.

The RS-232 port provides two-way serial digital communications to and from the CPU. These, and all of the above electrical interface signals are described in detail in chapter 3 *Installation*.

2.4. Temperature Control

For accurate analysis the sensor of this instrument is temperature controlled to 60°C.

Installation

Installation of the Model 2000A Analyzer includes:

1. Unpacking
2. Mounting
3. Gas connections
4. Electrical connections
5. Installing the Sensor
6. Testing the system.

3.1 Unpacking the Analyzer

The analyzer is shipped ready to install and prepare for operation. Carefully unpack the analyzer and inspect it for damage. Immediately report any damage to the shipping agent.

The four gas fittings that mate with the 1/8 NPT gas ports on the Model 2000A, are not included. They must be supplied by the customer.

3.2 Mounting the Analyzer

The Model 2000A is for indoor use in a general purpose area. It is NOT for hazardous environments of any type. It must be protected from:

- Direct sunlight
- Drafts of air
- Shock and vibration
- Temperatures below 30 °F (-1 °C) or above 110 °F (43 °C).

Locate the 2000A as close as possible, subject to the above conditions, to the sample point to minimize effects of sample line lag time on the analysis.

The standard model is designed for flush panel mounting. Figure 3-1 is an illustration of the 2000A standard front panel and mounting bezel. There

are four mounting holes—one in each corner of the rigid frame. Figure 3-1a contains the hole pattern dimensions. See the outline drawing, at the back of this manual for overall dimensions.

On special order, a 19" rack-mounting panel can be provided. For rack mounting, one or two 2000A series analyzers are flush-panel mounted on the rack panel. See Figure 3-1b for dimensions of the mounting panel.

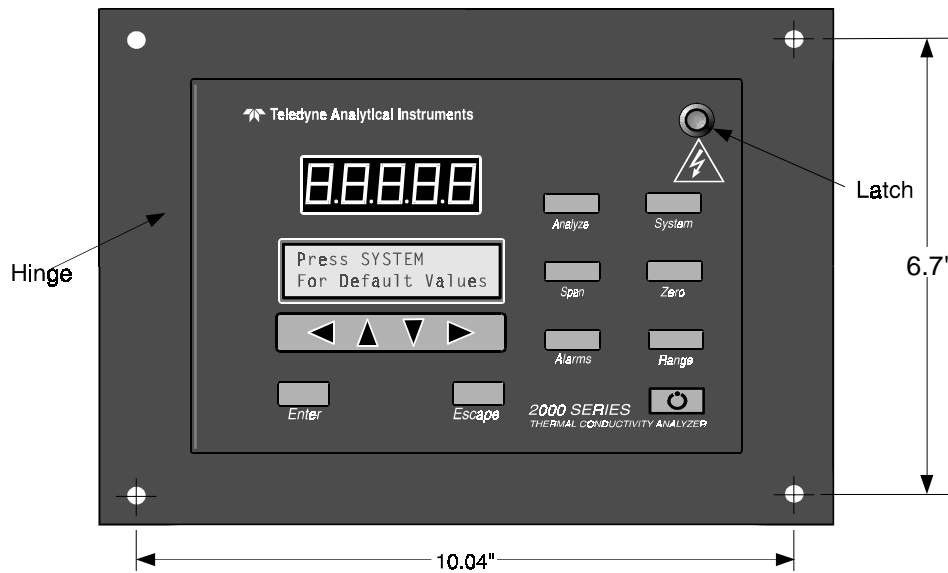

Figure 3-1a: Front Panel of the Model 2000A

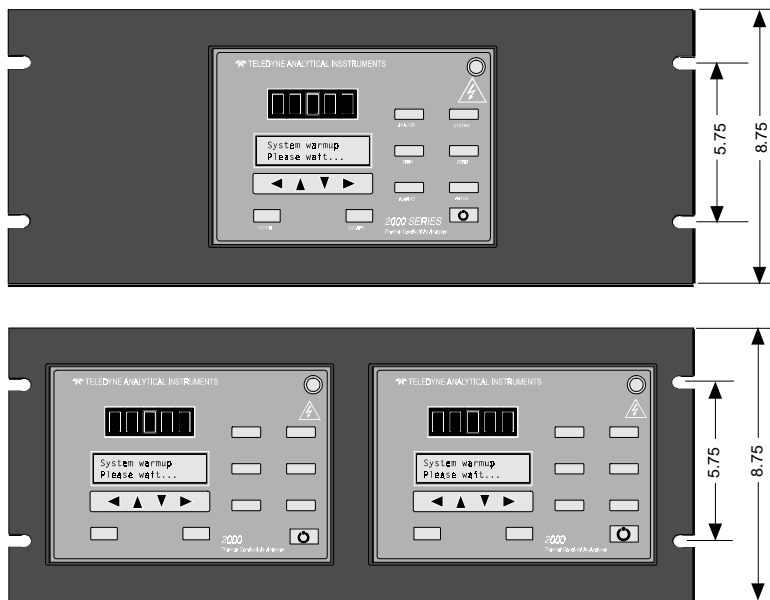

Figure 3-1b: Single and Dual 19" Rack Mounts

All operator controls are mounted on the control panel, which is hinged on the left edge and doubles as the door that provides access to the sensor inside the instrument. The door is spring loaded and will swing open when the button in the center of the latch (upper right corner) is pressed all the way in with a narrow gauge tool (less than 4.5 mm wide), such as a small hex wrench or screwdriver. Allow clearance for the door to open in a 90-degree arc of radius 19.3 cm. See Figure 3-2.

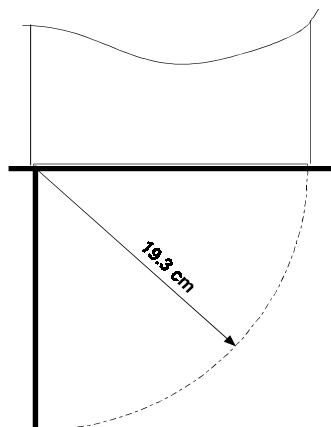

Figure 3-2: Required Front Door Clearance

3.3 Electrical Connections (Rear Panel)

Figure 3-3 shows the Model 2000A-EU rear panel. There are connectors for power, digital communications, and both digital and analog concentration output.

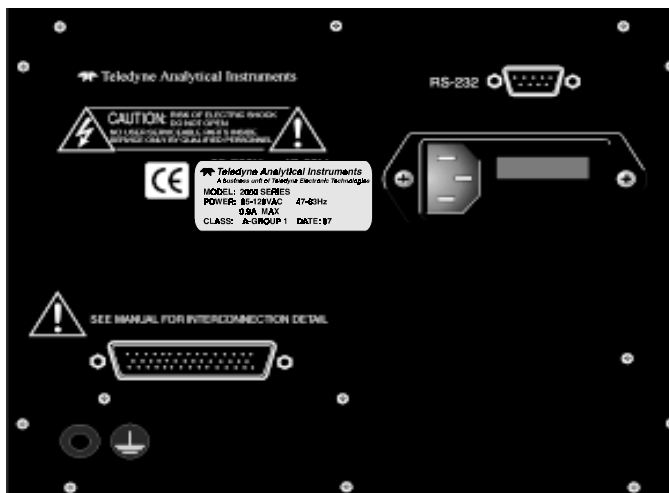

Figure 3-3: Rear Panel of the Model 2000A-EU

For safe connections, no uninsulated wiring should be able to come in contact with fingers, tools or clothing during normal operation.

CAUTION: *Use Shielded Cables. Also, use plugs that provide excellent EMI/RFI protection. The plug case must be connected to the cable shield, and it must be tightly fastened to the analyzer with its fastening screws. Ultimately, it is the installer who ensures that the connections provide adequate EMI/RFI shielding.*



3.3.1 Primary Input Power

The power cord receptacle and fuse block are located in the same assembly. Insert the power cord into the power cord receptacle.

DANGER: *POWER IS APPLIED TO THE INSTRUMENT'S CIRCUITRY AS LONG AS THE INSTRUMENT IS CONNECTED TO THE POWER SOURCE. THE STANDBY ON THE FRONT PANEL IS FOR SWITCHING POWER ON OR OFF TO THE DISPLAYS AND OUTPUTS ONLY.*

The standard power supply requires a 110 V ac, 50-60 Hz power source. If you have the -N option, you will require 220 V ac, 50-60 Hz power.

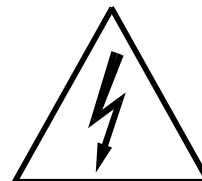

3.3.2 Fuse Installation

The fuse block, at the right of the power cord receptacle, accepts US or European size fuses. A jumper replaces the fuse in whichever fuse receptacle is not used. Fuses are not installed at the factory. Be sure to install the proper fuse as part of installation. (See *Fuse Replacement* in chapter 5, *maintenance*.)

3.3.3 50-Pin Equipment Interface Connector

Figure 3-4 shows the pin layout of the Equipment Interface connector. The arrangement is shown as seen when the viewer faces the rear panel of the analyzer. The pin numbers for each input/output function are given where each function is described in the paragraphs below.

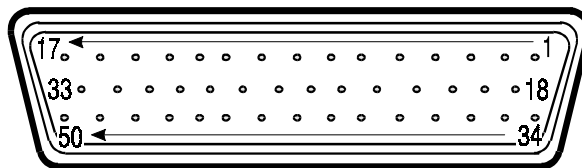

Figure 3-4: Equipment Interface Connector Pin Arrangement

3.3.3.1 Analog Outputs

There are four DC output signal pins—two pins per output. For polarity, see Table 3-1. The outputs are:

- 0–1 V dc % of Range: Voltage rises linearly with increasing concentration, from 0 V at 0 concentration to 1 V at full scale. (Full scale = 100% of programmable range.)
- 0–1 V dc Range ID: 0.25 V = Range 1, 0.5 V = Range 2, 0.75 V = Range 3, 1 V = Cal Range.
- 4–20 mA dc % Range: Current rises linearly with concentration, from 4 mA at 0 concentration to 20 mA at full scale. (Full scale = 100% of programmable range.)
- 4–20 mA dc Range ID: 8 mA = Range 1, 12 mA = Range 2, 16 mA = Range 3, 20 mA = Range 4.

Table 3-1: Analog Output Connections

Pin	Function
3	+ Range ID, 4-20 mA, floating
4	– Range ID, 4-20 mA, floating
5	+ % Range, 4-20 mA, floating
6	– % Range, 4-20 mA, floating
8	+ Range ID, 0-1 V dc
23	– Range ID, 0-1 V dc, negative ground
24	+ % Range, 0-1 V dc
7	– % Range, 0-1 V dc, negative ground

Examples:

The analog output signal has a voltage which depends on gas concentration **relative** to the full scale of the range. To relate the signal output to the actual concentration, it is necessary to know what range the instrument is currently on, especially when the analyzer is in the autoranging mode.

The signal output for concentration is linear over the currently selected analysis range. For example, if the analyzer is set on a range that was defined as 0–10 % hydrogen, then the output would be as shown in Table 3-2.

Table 3-2: Analog Concentration Output—Example

Percent Hydrogen	Voltage Signal Output (V dc)	Current Signal Output (mA dc)
0	0.0	4.0
1	0.1	5.6
2	0.2	7.2
3	0.3	8.8
4	0.4	10.4
5	0.5	12.0
6	0.6	13.6
7	0.7	15.2
8	0.8	16.8
9	0.9	18.4
10	1.0	20.0

To provide an indication of the range, the Range ID analog outputs are used. They generate a steady preset voltage (or current when using the current outputs) to represent a particular range. Table 3-3 gives the range ID output for each analysis range.

Table 3-3: Analog Range ID Output—Example

Range	Voltage (V)	Current (mA)	Application
Range 1	0.25	8	0-1 % H ₂ in N
Range 2	0.50	12	0-10 % H ₂ in N
Range 3	0.75	16	0-1 % H ₂ in Air
Range 4 (Cal)	1.00	20	0-1 % H ₂ in N

3.3.3.2 Alarm Relays

The nine alarm-circuit connector pins connect to the internal alarm relay contacts. Each set of three pins provides one set of Form C relay contacts. Each relay has both normally open and normally closed contact connections. The contact connections are shown in Table 3-4. They are

capable of switching up to 3 amperes at 250 V ac into a resistive load. The connectors are:



Threshold Alarm 1:

- Can be configured as high (actuates when concentration is above threshold), or low (actuates when concentration is below threshold).
- Can be configured as failsafe or nonfailsafe.
- Can be configured as latching or nonlatching.
- Can be configured out (defeated).

Threshold Alarm 2:

- Can be configured as high (actuates when concentration is above threshold), or low (actuates when concentration is below threshold).
- Can be configured as failsafe or nonfailsafe.
- Can be configured as latching or nonlatching.
- Can be configured out (defeated).

System Alarm: Actuates when DC power supplied to circuits is unacceptable in one or more parameters. Permanently configured as failsafe and latching. Cannot be defeated. Actuates if self test fails.

(Reset by pressing  button to remove power. Then press  again and any other button EXCEPT *System* to resume.

Further detail can be found in chapter 4, section 4-5.

Table 3-4: Alarm Relay Contact Pins

Pin	Contact
45	Threshold Alarm 1, normally closed contact
28	Threshold Alarm 1, moving contact
46	Threshold Alarm 1, normally open contact
42	Threshold Alarm 2, normally closed contact
44	Threshold Alarm 2, moving contact
43	Threshold Alarm 2, normally open contact
36	System Alarm, normally closed contact
20	System Alarm, moving contact
37	System Alarm, normally open contact

3.3.3.3 Digital Remote Cal Inputs

Accept 0 V (off) or 24 V dc (on) inputs for remote control of calibration. (See *Remote Calibration Protocol* below.) See Table 3-5 for pin connections.

- Zero:** Floating input. A 5 to 24 V pulse input across the + and – pins puts the analyzer into the *Zero* mode. Either side may be grounded at the source of the signal. A synchronous signal must open and close the gas control valves appropriately. See 3.3.3.6 *Remote Probe Connector*. (With the –C option the internal valves operate automatically.)
- Span:** Floating input. A 5 to 24 V pulse input across the + and – pins puts the analyzer into the *Span* mode. Either side may be grounded at the source of the signal. A synchronous signal must open and close the gas control valves appropriately. See 3.3.3.6 *Remote Probe Connector*. (With the –C option, the internal valves operate automatically.)

Cal Contact: This relay contact is closed while analyzer is spanning and/or zeroing. (See *Remote Calibration Protocol* below.)

Table 3-5: Remote Calibration Connections

Pin	Function
9	+ Remote Zero
11	– Remote Zero
10	+ Remote Span
12	– Remote Span
40	Cal Contact
41	Cal Contact

Remote Calibration Protocol: To properly time the Digital Remote Cal Inputs to the Model 2000A Analyzer, the customer's controller must monitor the Cal Relay Contact.

When the contact is OPEN, the analyzer is analyzing, the Remote Cal Inputs are being polled, and a zero or span command can be sent.

When the contact is CLOSED, the analyzer is already calibrating. It will ignore your request to calibrate, and it will not remember that request.

Once a zero or span command is sent, and acknowledged (contact closes), release it. If the command is continued until after the zero or span is complete, the calibration will repeat and the Cal Relay Contact (CRC) will close again.

For example:

- 1) Test the CRC. When the CRC is open, Send a zero command until the CRC closes (The CRC will close quickly.)
- 2) When the CRC closes, remove the zero command.

- 3) When CRC opens again, send a span command until the CRC closes. (The CRC will close quickly.)
- 4) When the CRC closes, remove the span command.

When CRC opens again, zero and span are done, and the sample is being analyzed.

Note: The Remote Probe connector (paragraph 3.3.3.6) provides signals to operate the zero and span gas valves synchronously. However, if you have the –C Internal valve option, which includes zero and span gas inputs, the 2000A automatically regulates the zero, span and sample gas flow.

3.3.3.4 Range ID Relays

Four dedicated Range ID relay contacts. For any single application they are assigned to relays in ascending order. For example: if all ranges have the same application, then the lowest range is assigned to the Range 1 ID relay, and the highest range is assigned to the Range 3 ID relay. Range 4 is the Cal Range ID relay. Table 3-6 lists the pin connections.

Table 3-6: Range ID Relay Connections

Pin	Function
21	Range 1 ID Contact
38	Range 1 ID Contact
22	Range 2 ID Contact
39	Range 2 ID Contact
19	Range 3 ID Contact
18	Range 3 ID Contact
34	Range 4 ID Contact
35	Range 4 ID Contact

3.3.3.5 Network I/O

A serial digital input/output for local network protocol. At this printing, this port is not yet functional. It is to be used in future options to the instrument. Pins 13 (+) and 29 (–).

3.3.3.6 Remote Valve Connector

The 2000A is a single-chassis instrument, which has no Remote Probe Unit. Instead, the Remote Valve connector is used as another method for controlling external sample/zero/span gas valves. See Figure 3-5.

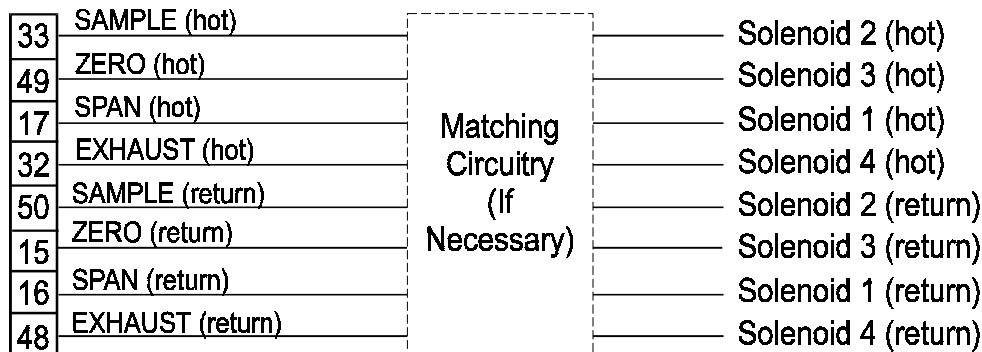

Figure 3-5: Remote Probe Connector Pinouts

The voltage from these outputs is nominally 0 V for the OFF and 15 V dc for the ON conditions. The maximum combined current that can be pulled from these output lines is 100 mA. (If two lines are ON at the same time, each must be limited to 50 mA, etc.) If more current and/or a different voltage is required, use a relay, power amplifier, or other matching circuitry to provide the actual driving current.

In addition, each individual line has a series FET with a nominal ON resistance of 5 ohms (9 ohms worst case). This could limit the obtainable voltage, depending on the load impedance applied. See Figure 3-7.

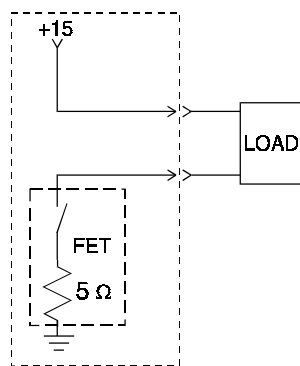

Figure 3-6: FET Series Resistance

3.3.4 RS-232 Port

The digital signal output is a standard RS-232 serial communications port used to connect the analyzer to a computer, terminal, or other digital device. It requires a standard 9-pin D connector.

Output: The data output is status information, in digital form, updated every two seconds. Status is reported in the following order:

- The concentration in ppm or percent

- The range in use (00 = Range 1, 01 = Range 2, 10 = Range 3, 11 = Range 4)
- The span of the range (0-100 %, etc)
- Which alarms—if any—are disabled (AL-x DISABLED)
- Which alarms—if any—are tripped (AL-x ON).

Each status output is followed by a carriage return and line feed.

Input: The input functions using RS-232 that have been implemented to date are described in Table 3-7.

Table 3-7: Commands via RS-232 Input

Command	Description
as<enter>	Immediately starts an autospan.
az<enter>	Immediately starts an autozero.
rp<enter>	Allows reprogramming of two <i>System</i> functions: APPLICATION (gas use) and ALGORITHM (linearization).
st<enter>	Toggling input. Stops/Starts any status message output from the RS-232, until st<enter> is sent again.

Implementation: The RS-232 protocol allows some flexibility in its implementation. Table 3-8 lists certain RS-232 values that are required by the Model 2000A implementation.

Table 3-8: Required RS-232 Options

Parameter	Setting
Baud	2400
Byte	8 bits
Parity	none
Stop Bits	1
Message Interval	2 seconds

3.4 Gas Connections

The gas fittings are accessed through holes on the underside of the analyzer chassis, as shown in Figure 3-8. Use 1/8 NPT threaded conversion fittings to convert pipe to tube for these connectors.

There are no gas control valves inside the main chassis. A sample system must be provided for introduction of zero and span gas, as well as sample gas, into the sample path, and for controlling the flowrates through the sample and reference paths of the analyzer.

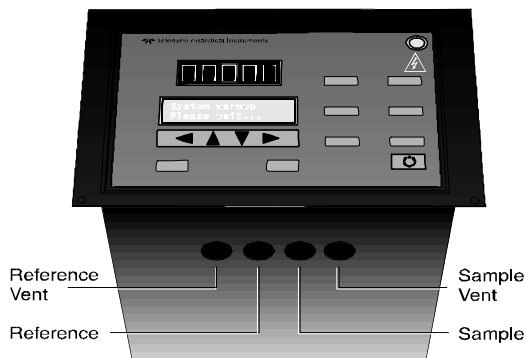
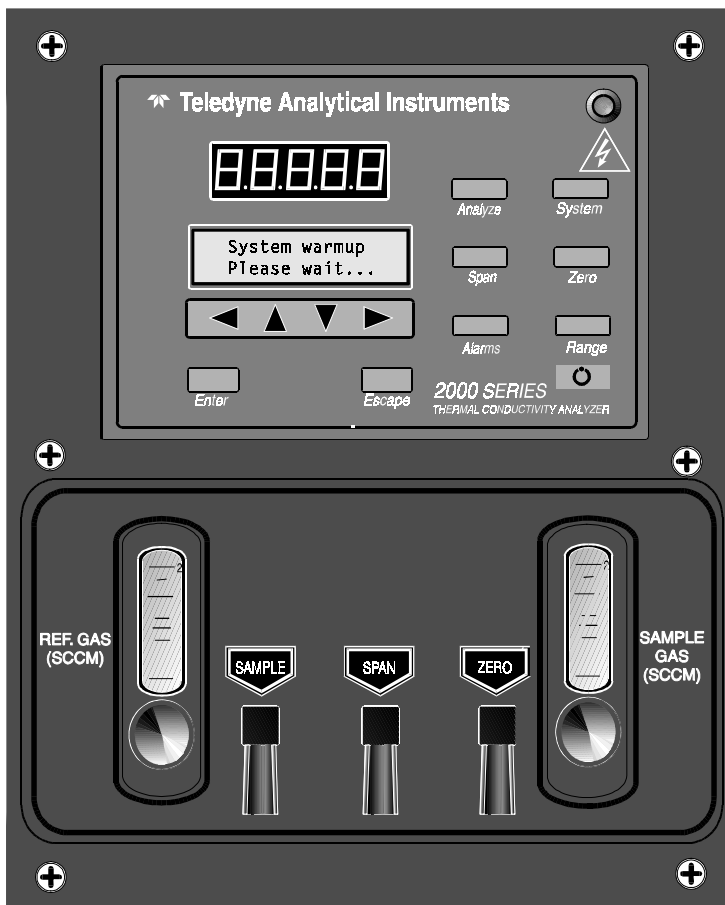

Figure 3-8: Gas Connections to the Basic Unit

If you have purchased a gas control panel from Analytical Instruments, the drawings at the back of this manual will contain a dimension outline drawing, with the modified cutout and hole pattern for mounting, and a drawing and/or addendum showing the gas connections.



Front Panel with optional selector panel (as shown)

3.4.1 Sample System Design

Gas Connector and Control Panels for specific applications are available as extra cost additions. These panels are usually designed around a standard manifold that attaches to the Model 2000A series analyzer below the front panel.

For those customers wishing to incorporate their own sample system, electronic input/output ports are provided on the rear panel for the operation of solenoid valves under the complete control of the Model 2000A electronics. See section 3.3. The recommended system piping schematic is included among the drawings at the rear of the manual.

The unit is manufactured with $\frac{1}{4}$ inch tubing and $\frac{1}{8}$ NPT threaded ports. The customer must provide matching fittings.

For best results, use the recommended piping system. Select a flowmeter that can resolve 40-50 cc/min (0.08 scfh) for the reference path of the analyzer, and select a flowmeter that can resolve 150 cc/min (0.3 scfh) for the sample path of the analyzer.

Note: The sample-line pressure regulator should be installed as close to the sample point as possible to minimize sample-line lag time.

3.4.2 Pressure and Flowrate Regulation

Appropriate pressure reducing regulators must be installed at all gas supply sources. To minimize flowrate adjustments the pressure regulators on the supporting gas supply cylinders should be adjusted to provide the same output pressure as the sample line regulator.

The gas pressure input should be reasonably well regulated. Pressures between 3.5 and 35 bar (5 - 50 psig) are acceptable—7 bar (10 psig) is normal) as long as the pressure, once established, will **keep the flow constant** during analysis, and within 50-200 cc/min (between 0.1 and 0.4 scfh). See Note.

Note: Gases lighter than air have a flowrate higher than indicated on the flowmeter, while gases heavier than air have a flowrate lower than indicated. Values can range from one half to twice the indicated flowrate.

For example: For hydrogen or helium, set the flowrate to 50 cc/min (0.1 scfh). For carbon dioxide or argon, set the flowrate to 200 cc/min (0.4 scfh).

When installing pressure regulators on supply cylinders, crack the cylinder valves so that gas is flowing during installation. This will eliminate the most common cause of standardization-gas contamination: air trapped during assembly diffusing back into the cylinder. This procedure is particularly important in applications where impurity content of 1 to 2 % is the range of interest.

Note: If you have the –V option, The above pressure and flow values apply instead to the vacuum at the VENT connector, described below, with minus signs before the pressure readings.

3.4.3 VENT Exhaust

There are two separate VENT fittings—one for the sample gas and one for the reference gas. Use 6 mm tubing for both sample and reference vents to minimize back pressure from restricted flow.

Exhaust connections must be consistent with the hazard level of the constituent gases. Check local, state, and federal laws, and ensure that the exhaust stream vents to an appropriately controlled area if required. If not vented to the same area, both VENT lines must vent to areas with equal ambient pressures, and pressures must vary no more than the normal barometric changes.

Install VENT lines such that water and dirt cannot accumulate in them.

Note: If your 2000A has the –V option, see Note at end of *Pressure and Flow Rate Regulation*, above, for gas flow considerations.

3.4.4 SAMPLE Gas

In the standard model, sample and calibration gases are introduced through the SAMPLE fitting. The gases must be Tee'd into the Sample inlet with appropriate valves.

The gas pressure in should be well regulated. (See section 3.4.1.) The sample line pressure regulator should be installed as close to the sample line as possible to minimize sample line lag time.

If greater flow is required for improved response time, install a bypass in the sampling system upstream of the analyzer input.

3.4.5 REFERENCE Gas

A gas of fixed composition is needed as a reference to which the sample gas will be compared. The reference gas is normally selected to represent the main background gas of the analysis.

For most applications, a constant supply of reference gas flowing at the same rate as the sample is required for best results. However, in many cases the flow of reference gas can be slowed to about 0.08 scfh (40 cc/min) with good results.

For some applications, an optional sealed air reference is installed. In sealed-reference sensors the reference side of the detector cell is filled with air and sealed. This eliminates the need to have reference gas constantly passing through the cell.

NOTE: For instruments equipped with the optional sealed air reference, there is no REFERENCE inlet or reference VENT port.

It is highly recommended that the same cylinder of gas be used for both the REFERENCE gas and the ZERO gas.

Pressure, flow, and safety considerations are the same as prescribed for the SAMPLE gas, above.

3.4.6 ZERO Gas

For the ZERO gas, a supply of the background gas, usually containing none of the impurity, is required to zero the analyzer during calibration. For suppressed zero ranges the zero gas must contain the low-end concentration of the impurity.

NOTE: Because most cylinder gases are between 99.95 and 99.98% pure, it is highly recommended that the same cylinder of gas be used for both REFERENCE and ZERO gas.

NOTE: It is essential to the accuracy of the analyzer that the purity of the zero gas be known. Otherwise, when the zero control is adjusted during zero standardization, the reading will indicate the impurity content of the zero gas, rather than zero.

3.4.7 SPAN Gas

For the SPAN gas, a supply of the background gas containing 80-100 % of the component of interest is required as a minimum. If linearization is required, intermediate concentrations of the target gas in the background gas may be necessary. From one to nine separate span gases may be

used, depending on the desired precision of the linearization. See chapter 4, *Operation*.

3.5 Testing the System

Before plugging the instrument into the power source:

- Check the integrity and accuracy of the gas connections. Make sure there are no leaks.
- Check the integrity and accuracy of the electrical connections. Make sure there are no exposed conductors
- Check that the pressure and flow of all gases are within the recommended levels, and appropriate for your application.

Power up the system, and test it by performing the following operations:

1. Repeat the Self-Diagnostic Test as described in chapter 4, section 4.3.5.

3.6 Warm Up at Power Up

Every time the unit is turned on, the instrument stays with the introduction screen for thirty minutes. This is to allow the cell to come up to temperature (60°C). The only way to bypass this warm up period is by pressing any key once, such as the *Enter* key.

The instrument warms up for half an hour so that it will not receive a remote calibration signal, send false readings to a monitor system, or, again, be calibrated by an untrained operator while the cell is cold.

NOTE: There is not feedback on whether the working temperature has been achieved by cell to the software. If instrument power is interrupted for only a brief time, the instrument will wait thirty minutes again.

Operation

4.1 Introduction

Although the Model 2000 is usually programmed to your application at the factory, it can be further configured at the operator level, or even, **cautiously**, reprogrammed. Depending on the specifics of the application, this might include all or a subset of the following procedures:

- Setting system parameters:
 - Establish a security password, if desired, requiring Operator to log in.
 - Establish and start an automatic calibration cycle, if desired.
- Routine Operation:
 - Calibrate the instrument.
 - Choose autoranging or select a fixed range of analysis.
 - Set alarm setpoints, and modes of alarm operation (latching, failsafe, etc).
- Program/Reprogram the analyzer:
 - Define new applications.
 - Linearize your ranges.

If you choose not to use password protection, the default password is automatically displayed on the password screen when you start up, and you simply press *Enter* for access to all functions of the analyzer.

4.2 Using the Data Entry and Function Buttons

Data Entry Buttons: The <> buttons select options from the menu currently being displayed on the VFD screen. The selected option blinks.

When the selected option includes a modifiable item, the Δ ∇ arrow buttons can be used to increment or decrement that modifiable item.

The *Enter* button is used to accept any new entries on the VFD screen. The *Escape* button is used to abort any new entries on the VFD screen that are not yet accepted by use of the *Enter* button.

Figure 4-1 shows the hierarchy of functions available to the operator via the function buttons. The six function buttons on the analyzer are:

- **Analyze.** This is the normal operating mode. The analyzer monitors the thermal conductivity of the sample, displays the percent or parts-per-million of target gas or contamination, and warns of any alarm conditions.
- **System.** The system function consists of nine subfunctions.

Four of these are for ordinary setup and operation:

- Setup an Auto-Cal
- Assign Passwords
- Log out to secure system
- Initiate a Self-Test

Three of the subfunctions do auxiliary tasks:

- Checking model and software version
- Adjust LCD screen contrast
- Display more subfunctions

Contrast Function is *DISABLED*
(Refer to Section 1.6)



Two of these are for programming/reprogramming the analyzer:

- Define gas applications and ranges (Refer to programming section, or contact factory.)
- Use the Curve Algorithm to linearize output. (Refer to programming section, or contact factory.)
- **Zero.** Used to set up a zero calibration.
- **Span.** Used to set up a span calibration.
- **Alarms.** Used to set the alarm setpoints and determine whether each alarm will be active or defeated, HI or LO acting, latching, and/or failsafe.
- **Range.** Used to set up three analysis ranges that can be switched automatically with autoranging or used as individual fixed ranges.

Any function can be selected at any time by pressing the appropriate button (unless password restrictions apply). The order as presented in this manual is appropriate for an initial setup.

Each of these functions is described in greater detail in the following procedures. The VFD screen text that accompanies each operation is reproduced, at

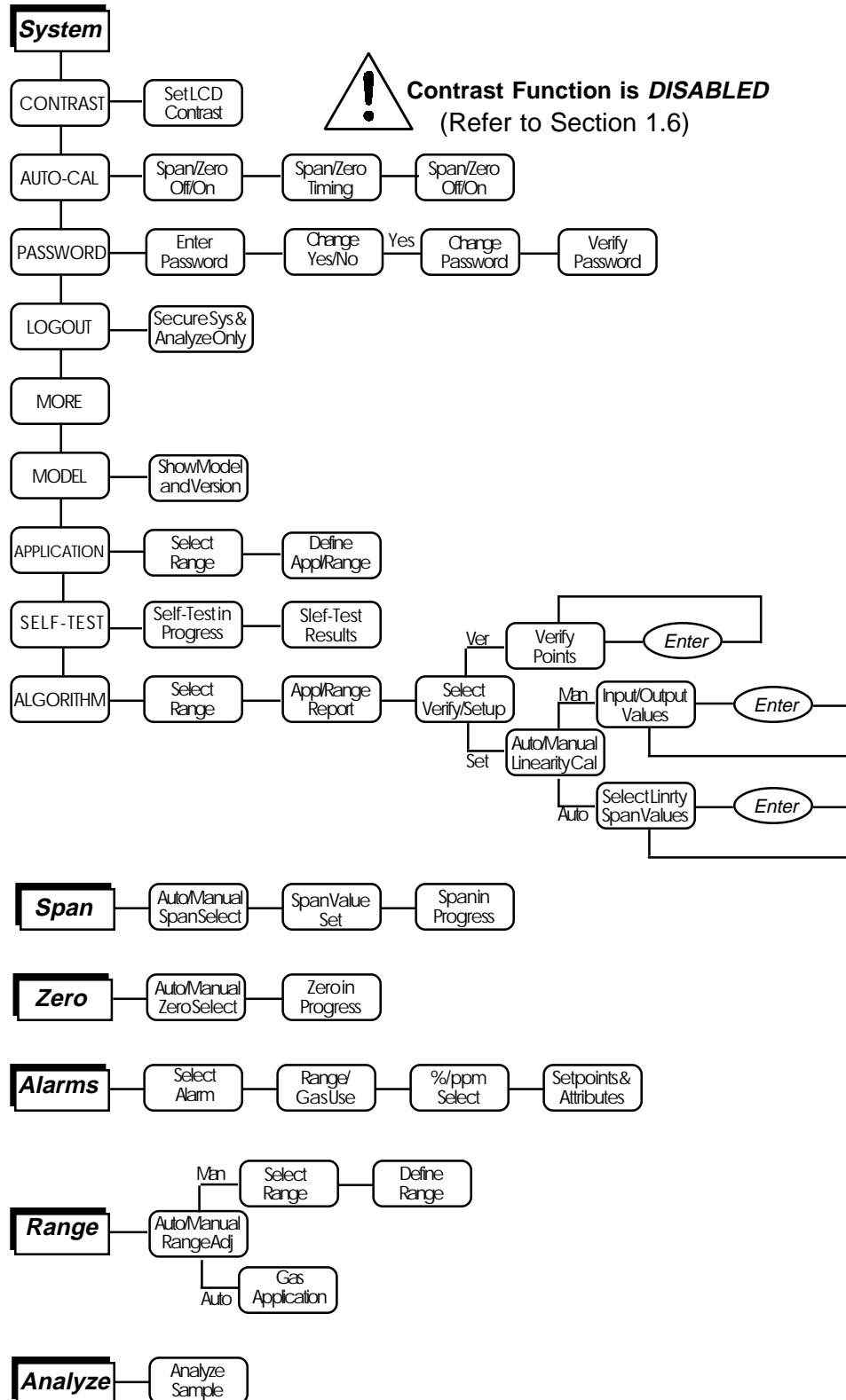

Figure 4-1: Hierarchy of Functions and Subfunctions

the appropriate point in the procedure, in a `Monospaced` type style. Pushbutton names are printed in *Oblique* type.

4.3 The *System* Function

The subfunctions of the *System* function are described below. Specific procedures for their use follow the descriptions:

- **AUTO-CAL:** Used to define an automatic calibration sequence and/or start an AUTO-CAL.
- **PWD:** Security can be established by choosing a 3 digit password (PWD) from the standard ASCII character set. Once a unique password is assigned and activated, the operator **MUST** enter the **UNIQUE** password to gain access to set-up functions which alter the instrument's operation.
- **LOGOUT:** Logging out prevents an unauthorized tampering with analyzer settings.
- **MORE:** Select and enter MORE to get a new screen with additional subfunctions listed.
- **MODEL:** Displays Manufacturer, Model, and Software Version of instrument.
- **APPLICATION:** A restricted function, not generally accessed by the end user. Used to define up to three analysis ranges and a calibration range (including impurity, background, low end of range, high end of range, and % or ppm units).
- **SELF-TEST:** The instrument performs a self-diagnostic test to check the integrity of the power supply, output boards, sensor cell, and preamplifiers.
- **ALGORITHM:** A restricted function, not generally accessed by the end user. Used to linearize the output for the range of interest.

4.3.1 Setting the Display

Contrast Function is **DISABLED**
(Refer to Section 1.6)



If you cannot read anything on the display after first powering up:

1. Observe LED readout.
 - a. If LED meter reads **8.8.8.8.8.**, go to step 3.
 - b. If LED meter displays anything else, go to step 2.
2. Press  button twice to turn Analyzer OFF and ON again. LED meter should now read **8.8.8.8.8.** Go to step 3.

4.3.2 Setting up an AUTO-CAL

When proper automatic valving is connected (see chapter 3, *installation*), the Analyzer can cycle itself through a sequence of steps that automatically zero and span the instrument.

Note: Before setting up an AUTO-CAL, be sure you understand the *Zero* and *Span* functions as described in section 4.4, and follow the precautions given there.

Note: If you require highly accurate AUTO-CAL timing, use external AUTO-CAL control where possible. The internal clock in the Model 2000 is accurate to 2-3 %. Accordingly, internally scheduled calibrations can vary 2-3 % per day.

Note: If all your ranges are for the same gas application, then AUTO-CAL will calibrate whichever range you are in at the scheduled time for automatic calibration.

Note: If your ranges are configured for different applications, then AUTO-CAL will calibrate all of the ranges simultaneously (by calibrating the Cal Range).

To setup an Auto-Cal cycle:

Choose *System* from the Function buttons. The VFD will display five subfunctions.



Contrast Function is **DISABLED** CONTRAST AUTO-CAL
(Refer to Section 1.6) PWD LOGOUT MORE

Use < > arrows to blink AUTO-CAL, and press *Enter*. A new screen for ZERO/SPAN set appears.

```
ZERO i n 0d 0h off
SPAN i n 0d 0h off
```

Press <> arrows to blink SPAN (or ZERO), then press *Enter* again. (*You won't be able to set OFF to ON if a zero interval is entered.*) A Span Every ... (or Zero Every ...) screen appears.

```
Zero schedul e: OFF
Day: 0d Hour: 0h
```

Use $\Delta\nabla$ arrows to set an interval value, then use <> arrows to move to the start-time value. Use $\Delta\nabla$ arrows to set a start-time value.

To turn ON the SPAN and/or ZERO cycles (to activate AUTO-CAL): Press *System* again, choose AUTO-CAL, and press *Enter* again. When the ZERO/SPAN values screen appears, use the <> arrows to blink the SPAN (or ZERO) and press *Enter* to go to the next screen. Use <> to select OFF/ON field. Use $\Delta\nabla$ arrows to set the OFF/ON field to ON. You can now turn these fields ON because there is a nonzero span interval defined.

4.3.3 Password Protection

Before a unique password is assigned, the system assigns TAl by default. This password will be displayed automatically. The operator just presses the Enter key to be allowed total access to the instrument's features.

If a password is assigned, then setting the following system parameters can be done only after the password is entered: **alarm** setpoints, assigning a new **password, range/application** selections, and **curve algorithm** linearization. (APPLICATION and ALGORITHM are covered in the programming section.) However, the instrument can still be used for analysis or for initiating a self-test without entering the password. To defeat security the password must be changed back to TAl.

NOTE: If you use password security, it is advisable to keep a copy of the password in a separate, safe location.

4.3.3.1 Entering the Password

To install a new password or change a previously installed password, you must key in and *ENTER* the old password first. If the default password is in effect, pressing the *ENTER* button will enter the default TAl password for you.

Press *System* to enter the *System* mode.



Contrast Function is *DISABLED*
(Refer to Section 1.6)

CONTRAST AUTO-CAL
PWD LOGOUT MORE

Use the <> arrow keys to scroll the blinking over to PWD, and press *Enter* to select the password function. Either the default TAI password or AAA place holders for an existing password will appear on screen depending on whether or not a password has been previously installed.

Enter password:
T A I

or

Enter password:
A A A

The screen prompts you to enter the current password. If you are not using password protection, press *Enter* to accept TAI as the default password. If a password has been previously installed, enter the password using the <> arrow keys to scroll back and forth between letters, and the $\Delta\nabla$ arrow keys to change the letters to the proper password. Press *Enter* to enter the password.

In a few seconds, you will be given the opportunity to change this password or keep it and go on.

Change Password?
<ENT>=Yes <ESC>=No

Press *Escape* to move on, or proceed as in *Changing the Password*, below.

4.3.3.2 Installing or Changing the Password

If you want to install a password, or change an existing password, proceed as above in *Entering the Password*. When you are given the opportunity to change the password:

Change Password?
<ENT>=Yes <ESC>=No

Press *Enter* to change the password (either the default TAI or the previously assigned password), or press *Escape* to keep the existing password and move on.

If you chose *Enter* to change the password, the password assignment screen appears.

Select new password
T A I

Enter the password using the <> arrow keys to move back and forth between the existing password letters, and the $\Delta\nabla$ arrow keys to change the letters to the new password. The full set of 94 characters available for password use are shown in the table below.

Characters Available for Password Definition:

A	B	C	D	E	F	G	H	I	J
K	L	M	N	O	P	Q	R	S	T
U	V	W	X	Y	Z	[¥]	^
_	`	a	b	c	d	e	f	g	h
i	j	k	l	m	n	o	p	q	r
s	t	u	v	w	x	y	z	{	
}	→	!	"	#	\$	%	&	'	(
)	*	+	'	-	.	/	0	1	2
3	4	5	6	7	8	9	:	;	<
=	>	?	@						

When you have finished typing the new password, press *Enter*. A verification screen appears. The screen will prompt you to retype your password for verification.

Enter PWD To Veri fy:
A A A

Use the arrow keys to retype your password and press *Enter* when finished. Your password will be stored in the microprocessor and the system will immediately switch to the *Analyze* screen, and you now have access to all instrument functions.

If all alarms are defeated, the *Analyze* screen appears as:

Ø. Ø % H2 i n N2
RØ1: Ø – 1ØØ Anl z

If an alarm is tripped, the second line will change to show which alarm it is:

Ø. Ø % H2 i n N2
AL-1

NOTE: If you log off the system using the LOGOUT function in the system menu, you will now be required to re-enter the password to gain access to Alarm, and Range functions.

4.3.4 Logging Out



The LOGOUT function provides a convenient means of leaving the analyzer in a password protected mode without having to shut the instrument off. By entering LOGOUT, you effectively log off the instrument leaving the system protected against use until the password is reentered. To log out, press the *System* button to enter the *System* function.



Contrast Function is *DISABLED*
(Refer to Section 1.6)

```

CONTRAST    AUTO-CAL
PWD    LOGOUT    MORE
  
```

Use the   arrow keys to position the blinking over the LOGOUT function, and press *Enter* to Log out. The screen will display the message:

```

Protected until
password entered
  
```

4.3.5 System Self-Diagnostic Test

The Model 2000 has a built-in self-diagnostic testing routine. Pre-programmed signals are sent through the power supply, output board, preamp board and sensor circuit. The return signal is analyzed, and at the end of the test the status of each function is displayed on the screen, either as OK or as a number between 1 and 1024. (See *System Self Diagnostic Test* in chapter 5 for number code.) If any of the functions fails, the System Alarm is tripped.

Note: The sensor will always show failed unless identical gas is present in both channels at the time of the SELF-TEST.

The self diagnostics are run automatically by the analyzer whenever the instrument is turned on, but the test can also be run by the operator at will. To initiate a self diagnostic test during operation:



Press the *System* button to start the *System* function.



Contrast Function is *DISABLED*
(Refer to Section 1.6)

```

CONTRAST    AUTO-CAL
PWD    LOGOUT    MORE
  
```

Use the   arrow keys to blink MORE, then press *Enter*.

```

MODEL APPLI CATI ON
SELF-TEST  ALGORI THM
  
```

Use the < > arrow keys again to move the blinking to the SELF-TEST and press *Enter*. The screen will follow the running of the diagnostic.

```

RUNNI NG  DI AGNOSTI C
Testi ng Preamp - Cel I
  
```

When the testing is complete, the results are displayed.

Power: OK Anal og: OK
 Cel l : 2 Preamp: 3

The module is functioning properly if it is followed by OK. A number indicates a problem in a specific area of the instrument. Refer to Chapter 5 *Maintenance and Troubleshooting* for number-code information. The results screen alternates for a time with:

Press Any Key
 To Conti nue. . .

Then the analyzer returns to the initial System screen.

4.3.6 The Model Screen

Move the < > arrow key to MORE and press *Enter*. With MODEL blinking, press *Enter*. The screen displays the manufacturer, model, and software version information.

4.3.7 Checking Linearity with ALGORITHM

From the *System* Function screen, select ALGORITHM, and press *Enter*.

Range l i neari zati on
 -> 01 02 03 <-

Use the < > keys to select the range: 01, 02, or 03. Then press *Enter*.

Range: 0 -16 %
 Gas use: 02 - N2

Press Enter again.

Al gori thm setup:
 VERI FY SET UP

Select and *Enter* VERIFY to check whether the linearization has been accomplished satisfactorily.

Dpt I NPUT OUTPUT
 0 0.00 0.00

The leftmost digit (under Dpt) is the number of the data point being monitored. Use the $\Delta \nabla$ keys to select the successive points.

The INPUT value is the input to the linearizer. It is the simulated output of the analyzer. **You do not need to actually flow gas.**

The OUTPUT value is the output of the linearizer. It should be the ACTUAL concentration of the span gas being simulated.

If the OUTPUT value shown is not correct, the linearization must be corrected. Press *ESCAPE* to return to the previous screen. Select and *ENTER SET UP* to Calibration Mode screen.

Select algorithm
mode : AUTO

There are two ways to linearize: AUTO and MANUAL: The auto mode requires as many calibration gases as there will be correction points along the curve. The user decides on the number of points, based on the precision required.

The manual mode only requires entering the values for each correction point into the microprocessor via the front panel buttons. Again, the number of points required is determined by the user.

4.4 The Zero and Span Functions

(1) The Model 2000 can have as many as three analysis ranges plus a special calibration range (Cal Range); and the analysis ranges, if more than one, may be programmed for separate or identical gas applications.

(2) If all ranges are for the same application, then you will not need the Cal Range. Calibrating any one of the ranges will automatically calibrate the others.

(3) If: a) each range is programmed for a different gas application, b) your sensor calibration has drifted less than 10 %, and c) your Cal Range was calibrated along with your other ranges when last calibrated, then you can use the Cal Range to calibrate all applications ranges at once.

If your Model 2000 analyzer fits the paragraph (3) description, above, use the Cal Range. If your analyzer has drifted more than 10 %, calibrate each range individually.

CAUTION: Always allow 4-5 hours warm-up time before calibrating, if your analyzer has been disconnected from its power source. This does not apply if the analyzer was plugged in but was in STANDBY.

The analyzer is calibrated using reference, zero, and span gases. Gas requirements are covered in detail in chapter 3, section 3.4 *Gas Connections*. Check that calibration gases are connected to the analyzer according to the instructions in section 3.4, observing all the prescribed precautions.

Note: Shut off the gas pressure before connecting it to the analyzer, and be sure to limit pressure to 40 psig or less when turning it back on.

Readjust the gas pressure into the analyzer until the flowrate through the sensor settles between 50 to 200 cc/min (approximately 0.1 to 0.4 scfh).

4.4.1 Zero Cal

The *Zero* button on the front panel is used to enter the zero calibration function. Zero calibration can be performed in either the automatic or manual mode.

CAUTION: *If you are zeroing the Cal Range by itself (multiple application analyzers only), use manual mode zeroing.*

If you want to calibrate ALL of the ranges at once (multiple application analyzers only), use auto mode zeroing in the Cal Range.

Make sure the zero gas is flowing to the instrument. If you get a CELL CANNOT BE BALANCED message while zeroing skip to section 4.4.1.3.

4.4.1.1 Auto Mode Zeroing

Observe the precautions in sections 4.4 and 4.4.1, above. Press *Zero* to enter the zero function mode. The screen allows you to select whether the zero calibration is to be performed automatically or manually. Use the $\Delta\nabla$ arrow keys to toggle between AUTO and MAN zero settling. Stop when AUTO appears, blinking, on the display.

```
Select zero
mode:  AUTO
```

Press *Enter* to begin zeroing.

```
#### % 02 - N2
Slope=##### C-Zero
```

The beginning zero level is shown in the upper left corner of the display. As the zero reading settles, the screen displays and updates information on Slope = in percent/second (unless the Slope starts within the acceptable zero range and does not need to settle further). The system first does a course zero, shown in the lower right corner of the screen as C—Zero, for 3 min, and then does a fine zero, and displays F—Zero, for 3 min.

Then, and whenever Slope is less than 0.01 for at least 3 min, instead of Slope you will see a countdown: 9 Left, 8 Left, and so fourth. These are software steps in the zeroing process that the system must complete, AFTER settling, before it can go back to *Analyze*. Software zero is indicated by S-Zero in the lower right corner.

```
##### % O2 - N2
4 Left=##### S-Zero
```

The zeroing process will automatically conclude when the output is within the acceptable range for a good zero. Then the analyzer automatically returns to the *Analyze* mode.

4.4.1.2 Manual Mode Zeroing

Press *Zero* to enter the *Zero* function. The screen that appears allows you to select between automatic or manual zero calibration. Use the ΔV keys to toggle between AUTO and MAN zero settling. Stop when MANUAL appears, blinking, on the display.

```
Select zero
mode:  MANUAL
```

Press *Enter* to begin the zero calibration. After a few seconds the first of three zeroing screens appears. The number in the upper left hand corner is the first-stage zero offset. The microprocessor samples the output at a predetermined rate.

```
#### % O2 - N2
Zero adj : 2048 C-Zero
```

The analyzer goes through C-Zero, F-Zero, and S-Zero. During C-Zero and F-Zero, use the ΔV keys to adjust displayed Zero adj: value as close as possible to zero. Then, press *Enter*.

S-Zero starts. During S-Zero, the Microcontroller takes control as in *Auto Mode Zeroing*, above. It calculates the differences between successive samplings and displays the rate of change as Slope = a value in parts per million per second (ppm/s).

Note: It takes several seconds for the true Slope value to display. Wait about 10 seconds. Then, wait until Slope is sufficiently close to zero before pressing *Enter* to finish zeroing.

```
#### % O2 - N2
Slope=##### C-Zero
```

Generally, you have a good zero when Slope is less than 0.05 ppm/s for about 30 seconds.

Once zero settling completes, the information is stored in the analyzer's memory, and the instrument automatically returns to the *Analyze* mode.

4.4.1.3 Cell Failure

Cell failure in the 2000 is usually associated with inability to zero the instrument with a reasonable voltage differential across the Wheatstone bridge. If this should ever happen, the 2000 system alarm trips, and the LCD displays a failure message.

```
CELL CANNOT BE BALANCED  
CHECK YOUR ZERO GAS
```

Before replacing the sensor:

- a. Check your zero gas to make sure it is within specifications.
- b. Check for leaks downstream from the sensor, where contamination may be leaking into the system.

If there are no leaks and the zero gas is OK, the sensor may need to be replaced. Check warranty, and contact Analytical Instruments Customer Service.

4.4.2 Span Cal

The *Span* button on the front panel is used to span calibrate the analyzer. Span calibration can be performed in either the automatic or manual mode.

CAUTION: If you are spanning the Cal Range by itself (multiple application analyzers only), use manual mode zeroing.

If you want to calibrate ALL of the ranges at once (multiple application analyzers only), use auto mode spanning in the Cal Range.

Make sure the span gas is flowing to the instrument.

4.4.2.1 Auto Mode Spanning

Observe all precautions in sections 4.4 and 4.4.2, above. Press *Span* to enter the span function. The screen that appears allows you to select whether the span calibration is to be performed automatically or manually. Use the $\Delta\nabla$

arrow keys to toggle between AUTO and MAN span settling. Stop when AUTO appears, blinking, on the display.

```
Select span  
mode:  AUTO
```

Press *Enter* to move to the next screen.

```
Span Val :  20.00 %  
<ENT> To begin span
```

Use the <> arrow keys to toggle between the span concentration value and the units field (%/ppm). Use the $\Delta\nabla$ arrow keys change the value and/or the units, as necessary. When you have set the concentration of the span gas you are using, press *Enter* to begin the Span calibration.

```
#### % O2 - N2  
Slope=##### Span
```

The beginning span value is shown in the upper left corner of the display. As the span reading settles, the screen displays and updates information on Slope. Spanning automatically ends when the span output corresponds, within tolerance, to the value of the span gas concentration. Then the instrument automatically returns to the analyze mode.

4.4.2.2 Manual Mode Spanning

Press *Span* to start the *Span* function. The screen that appears allows you to select whether the span calibration is to be performed automatically or manually.

```
Select span  
mode:  MANUAL
```

Use the $\Delta\nabla$ keys to toggle between AUTO and MAN span settling. Stop when MAN appears, blinking, on the display. Press *Enter* to move to the next screen.

```
Span Val :  20.00 %  
<ENT> To begin span
```

Use the <> arrow keys to toggle between the span concentration value and the units field (%/ppm). Use the $\Delta\nabla$ arrow keys change the value and/or the units, as necessary. When you have set the concentration of the span gas you are using, press *Enter* to begin the Span calibration.

Press *Enter* to enter the span value into the system and begin the span calibration.

Once the span has begun, the microprocessor samples the output at a predetermined rate. It calculates the difference between successive samplings and displays this difference as Slope on the screen. It takes several seconds for the first Slope value to display. Slope indicates rate of change of the Span reading. It is a sensitive indicator of stability.

```
##### % O2 – Air  
Slope=##### Span
```

When the Span value displayed on the screen is sufficiently stable, press *Enter*. (Generally, when the Span reading changes by 1 % or less of the range being calibrated for a period of ten minutes it is sufficiently stable.) Once *Enter* is pressed, the Span reading changes to the correct value. The instrument then **automatically** enters the *Analyze* function.

4.5 The Alarms Function

The Model 2000 is equipped with 2 fully adjustable concentration alarms and a system failure alarm. Each alarm has a relay with a set of form “C” contacts rated for 3 amperes resistive load at 250 V ac. See Figure in Chapter 3, *Installation* and/or the Interconnection Diagram included at the back of this manual for relay terminal connections.

The system failure alarm has a fixed configuration described in chapter 3 *Installation*.

The concentration alarms can be configured from the front panel as either *high* or *low* alarms by the operator. The alarm modes can be set as *latching* or *non-latching*, and either *failsafe* or *non-failsafe*, or, they can be *defeated* altogether. The setpoints for the alarms are also established using this function.

Decide how your alarms should be configured. The choice will depend upon your process. Consider the following four points:

1. Which if any of the alarms are to be high alarms and which if any are to be low alarms?

Setting an alarm as HIGH triggers the alarm when the contaminant concentration rises above the setpoint. Setting an alarm as LOW triggers the alarm when the contaminant concentration falls below the setpoint.

Decide whether you want the alarms to be set as:

- Both high (high and high-high) alarms, or
 - One high and one low alarm, or
 - Both low (low and low-low) alarms.
2. Are either or both of the alarms to be configured as failsafe?

In failsafe mode, the alarm relay de-energizes in an alarm condition. For non-failsafe operation, the relay is energized in an alarm condition. You can set either or both of the concentration alarms to operate in failsafe or non-failsafe mode.

3. Are either of the alarms to be latching?

In latching mode, once the alarm or alarms trigger, they will remain in the alarm mode even if process conditions revert back to non-alarm conditions. This mode requires an alarm to be recognized before it can be reset. In the non-latching mode, the alarm status will terminate when process conditions revert to non-alarm conditions.

4. Are either of the alarms to be defeated?

The defeat alarm mode is incorporated into the alarm circuit so that maintenance can be performed under conditions which would normally activate the alarms.

The defeat function can also be used to reset a latched alarm. (See procedures, below.)

If you are using password protection, you will need to enter your password to access the alarm functions. Follow the instructions in section 4.3.3 to enter your password. Once you have clearance to proceed, enter the *Alarm* function.

Press the *Alarm* button on the front panel to enter the *Alarm* function. Make sure that 01 is blinking.

```

Sel rng to set al m:
-> 01 02 03  <-

```

Set up the Range 1 alarm by moving the blinking over to 01 using the <> arrow keys. Then press *Enter*. Check the gas application and range limits as displayed on the screen.

```

Gas use: C3H8 – He
Range: 0 – 10 %

```

Press enter again to set the alarm setpoints.

```

Sel %/ppm al m to set
AL1-PPM AL2-PPM

```

Use the Δ ∇ keys to choose between % and ppm units. Then press *Enter* to move to the next screen.

```

AL1: 1000 ppm HI
Dft: N Fs: N Ltch: N

```

Five parameters can be changed on this screen:

- Value of the alarm setpoint, AL-1 #####
 - Out-of-range direction, HI or LO
 - Defeated? Dft: Y/N (Yes/No)
 - Failsafe? Fs: Y/N (Yes/No)
 - Latching? Ltch: Y/N (Yes/No).
- To define the setpoint, use the < > arrow keys to move the blinking over to AL-1 #####. Then use the Δ ∇ arrow keys to change the number. Holding down the key speeds up the incrementing or decrementing.
 - To set the other parameters use the < > arrow keys to move the blinking over to the desired parameter. Then use the Δ ∇ arrow keys to change the parameter.
 - Once the parameters for alarm 1 have been set, press *Alarms* again, and repeat this procedure for alarm 2 (AL2).
 - To reset a latched alarm, go to Dft- and then press either Δ two times or ∇ two times. (Toggle it to Y and then back to N.)

–OR –

Go to Ltch- and then press either Δ two times or ∇ two times.
(Toggle it to N and back to Y.)

4.6 The Range Select Function

The *Range* function allows you to manually select the concentration range of analysis (MANUAL), or to select automatic range switching (AUTO).

In the MANUAL screen, you are further allowed to define the high and low (concentration) limits of each Range, and select a single, fixed range to run.

CAUTION: If this is a linearized application, the new range must be within the limits previously programmed using the System function, if linearization is to apply throughout the range. Furthermore, if the limits are too small a part (approx 10 % or less) of the originally linearized range, the linearization will be compromised.

In the AUTO screen, you are further allowed to select which gas application (PREVIOUSLY defined in *System* function) to run.

4.6.1 Manual (Select/Define Range) Screen

The Manual range-switching mode allows you to select a single, fixed analysis range. It then allows you to redefine the upper and lower limits, for the range.

Press *Range* key to start the Range function.

```
Select range  
mode:  MANUAL
```

Note: If all three ranges are currently defined for different application gases, then the above screen does not display (because mode must be manual). Instead, the LCD goes directly to the following screen.

If above screen displays, use the $\Delta\nabla$ arrow keys to Select MANUAL, and press *Enter*.

```
Select range to run  
-> 01 02 03 CAL<-
```

Use the <> keys to select the range: 00, 01, 02, or 03. (04 is for future expansion.) Then press *Enter*.

```
Gas use:  02 - N2  
Range:   0 - 16 %
```

Use the <> keys to toggle between the Range: low-end field and the Range: high-end field. Use the $\Delta\nabla$ keys to change the values of the fields.

Press *Escape* to return to the previous screen to select or define another range.

Press *Enter* to return the to the *Analyze* function.

4.6.2 Auto (Single Application) Screen

The Auto screen requires you to select an application (previously defined in the *System* function). It then automatically places all ranges previously defined for that application in queue for automatic range switching.

In the autoranging mode, the microprocessor automatically responds to concentration changes by switching ranges for optimum readout sensitivity. If the upper limit of the operating range is reached, the instrument automatically shifts to the next higher range. If the concentration falls to below 85% of full scale of the next lower range, the instrument switches to the lower range. A corresponding shift in the DC concentration output, and in the range ID outputs, will be noticed.

The autoranging feature can be overridden so that analog output stays on a fixed range regardless of the contaminant concentration detected. If the concentration exceeds the upper limit of the range, the DC output will saturate at 1 V dc (20 mA at the current output).

However, the digital readout and the RS-232 output of the concentration are unaffected by the fixed range. They continue to read beyond the full-scale setting until amplifier saturation is reached. Below amplifier saturation, the overrange readings are accurate UNLESS the application uses linearization over the selected range.

The concentration ranges can be redefined using the *Range* function Manual screen, and the application gases can be redefined using the *System* function, **if** they are not already defined as necessary.

CAUTION: Redefining applications or ranges might require relinearization and/or recalibration.

To setup automatic ranging:

Press *Range* key to start the Range function.

```
Select range mode  
Range mode : AUTO
```

Note: If all three ranges are currently defined for different application gases, then the above screen does not display (because mode must be manual). Instead, the VFD goes directly to the following screen.

If above screen displays, use the $\Delta\nabla$ arrow keys to Select AUTO, and press *Enter*.

```
Select auto rangi ng  
Gas use: 02 – N2
```

Use the $\Delta\nabla$ arrow keys to change the application (gas use:).

Press *Escape* to return to the previous screen to select or define another range.

Press *Enter* to return the to the *Analyze* function.

4.6.3 Precautions

The Model 2000 allows a great deal of flexibility in choosing ranges for automatic range switching. However, there are some pitfalls that are to be avoided.

Ranges that work well together are:

- Ranges that have the same lower limits but upper limits that differ by approximately an order of magnitude
- Ranges whose upper limits coincide with the lower limits of the next higher range
- Ranges where there is a gap between the upper limit of the range and the lower limit of the next higher range.

Range schemes that are to be avoided include:

- Ranges that overlap
- Ranges whose limits are entirely within the span of an adjoining range.

Figure 4-2 illustrates these schemes graphically.

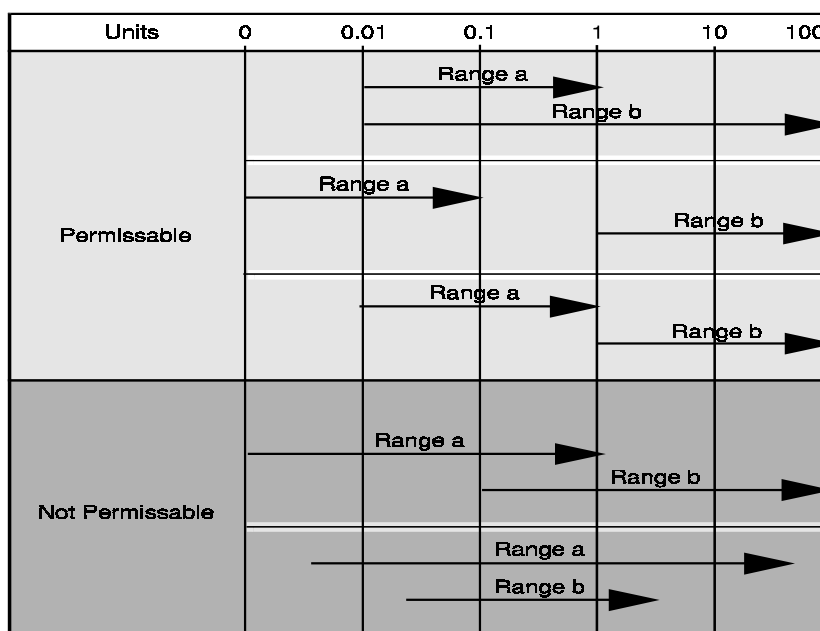

Figure 4-2: Examples of Autoranging Schemes

4.7 The *Analyze* Function

Normally, all of the functions automatically switch back to the *Analyze* function when they have completed their assigned operations. Pressing the *Escape* button in many cases also switches the analyzer back to the *Analyze* function. Alternatively, you can press the *Analyze* button at any time to return to analyzing your sample.

The *Analyze* function screen shows the impurity concentration and the application gases in the first line, and the range in the second line. In the lower

right corner, the abbreviation Anlz indicates that the analyzer is in the *Analyze* mode. If there is an * before the Anlz, it indicates that the range is linearized.

```
19.3 % O2 - Air
R: 00:0 -17 *Anlz
```

If the concentration detected is overrange, the first line of the display blinks continuously.

4.8 Programming

CAUTION: *The programming functions of the Set Range and Curve Algorithm screens are configured at the factory to the users application specification. These functions should only be reprogrammed by trained, qualified personnel.*

To program, you must:

1. Enter the password, if you are using the analyzer's password protection capability.
2. Connect a computer or computer terminal capable of sending an RS-232 signal to the analyzer RS-232 connector. (See chapter 3 *Installation* for details). Send the **rp** command to the analyzer.

OR

For software 1.1.4 or later, turn the instrument off and back on. While on the introduction screen hold the *Analyze* key for at least fifteen seconds. Press the *Enter* key twice to return to the Analyze mode.

3. Press the *System* button to start the *System* function.

```
CONTRAST    AUTO-CAL
PWD    LOGOUT    MORE
```

Use the <> arrow keys to blink MORE, then press *Enter*.

```
MODEL APPLI CATI ON
SELF_TEST ALGORI THM
```

Now you will be able to select the APPLICATION and ALGORITHM set-up functions.

Contrast Function is **DISABLED**
(Refer to Section 1.6)



4.8.1 The Set Range Screen

The Set Range screen allows reprogramming of the three analysis ranges and the calibration range (including impurity gas, background gas, low end of range, high end of range, and % or ppm units). Original programming is usually done at the factory according to the customer's application. It must be done through the RS-232 port using a computer running a terminal emulation program.

Note: It is important to distinguish between this *System* programming subfunction and the *Range* button function, which is an operator control. The Set Range Screen of the *System* function allows the user to DEFINE the upper and lower limits of a range AND the application of the range. The *Range* button function only allows the user to select or define the limits, or to select the application, but not to define the application.

Normally the Model 2000 is factory set to default to manual range selection, unless it is ordered as a single-application multiple-range unit (in which case it defaults to autoranging). In either case, autoranging or manual range selection can be programmed by the user.

In the autoranging mode, the microprocessor automatically responds to concentration changes by switching ranges for optimum readout sensitivity. If the upper limit of the operating range is reached, the instrument automatically shifts to the next higher range. If the concentration falls to below 85% of full scale of the next lower range, the instrument switches to the lower range. A corresponding shift in the DC concentration output, and in the range ID outputs, will be noticed.

The autoranging feature can be overridden so that analog output stays on a fixed range regardless of the contaminant concentration detected. If the concentration exceeds the upper limit of the range, the DC output will saturate at 1 V dc (20 mA at the current output).

However, the digital readout and the RS-232 output of the concentration are unaffected by the fixed range. They continue to read beyond the full-scale setting until amplifier saturation is reached. Below amplifier saturation, the overrange readings are accurate UNLESS the application uses linearization over the selected range.

To program the ranges, you must first perform the four steps indicated at the beginning of section 4.8 *Programming*. You will then be in the second *System* menu screen.

MODEL APPLICATION
SELF_TEST ALGORITHM

Use the < > arrow keys again to move the blinking to APPLICATION and press *Enter*.

```
Select rng to set appl :
-> 01 02 03 CAL <-
```

Use the $\Delta \nabla$ arrow keys to increment/decrement the range number to 0, 1, 2, or 3, and press *Enter*.

```
Imp: 02 Bck: N2
FR-0 TO-100 %
```

Use the < > arrow keys to move to Imp: (impurity), Bck: (background), FR: (from—lower end of range), TO: (to—upper end of range), and PPM or %.

Use the $\Delta \nabla$ arrow keys to increment the respective parameters as desired. Press *Enter* to accept the values and return to *Analyze* mode. (See note below.) Repeat for each range you want to set.

Note: The ranges must be increasing from low to high, for example, if Range 1 is set to 0–10 % and Range 2 is set to 0–100 %, then Range 3 cannot be set to 0–50 % since that makes Range 3 lower than Range 2.

Ranges, alarms, and spans are always set in either percent or ppm units, as selected by the operator, even though all concentration-data outputs change from ppm to percent when the concentration is above 9999 ppm.

Note: When performing analysis on a fixed range, if the concentration rises above the upper limit as established by the operator for that particular range, the output saturates at 1 V dc (or 20 mA). However, the digital readout and the RS-232 output continue to read regardless of the analog output range.

To end the session:

If started with the RS-232, send:

```
st<enter>
st<enter>
```

to the analyzer from the computer.

If started through the front panel, turn the instrument off and back on. Press the *Enter* key twice to return to the *Analyze* mode.

4.8.2 The Curve Algorithm Screen

The Curve Algorithm is a linearization method. It provides from 1 to 9 intermediate points between the ZERO and SPAN values, which can be normal-

ized during calibration, to ensure a straight-line input/output transfer function through the analyzer.

Each range is linearized individually, as necessary, since each range will usually have a totally different linearization requirement. **Before setting the algorithm curve, each range must be Zeroed and Spanned.**

To linearize the ranges, you must first perform the four steps indicated at the beginning of section 4.8 *Programming*. You will then be in the second *System* menu screen.

```
MODEL APPLI CATION
SELF_TEST ALGORI THM
```

4.8.2.1 Checking the linearization

From the *System* Function screen, select ALGORITHM, and press *Enter*.

```
Range l i neari zati on
-> 01 02 03 <-
```

Use the <> keys to select the range: 01, 02, or 03. Then press *Enter*.

```
Range: 0 -16 %
Gas use: 02 - N2
```

Press *Enter* again.

```
Al gori thm setup:
VERI FY SET UP
```

Select and *Enter* *VERIFY* to check whether the linearization has been accomplished satisfactorily.

```
Dpt I NPUT OUTPUT
0 0.00 0.00
```

The leftmost digit (under Dpt) is the number of the data point being monitored. Use the $\Delta \nabla$ keys to select the successive points.

The INPUT value is the input to the linearizer. It is the simulated output of the analyzer. **You do not need to actually flow gas.**

The OUTPUT value is the output of the linearizer. It should be the ACTUAL concentration of the span gas being simulated.

If the OUTPUT value shown is not correct, the linearization must be corrected. Press *ESCAPE* to return to the previous screen. Select and *ENTER* *SET UP* to Calibration Mode screen.

Select algorithm
mode : AUTO

There are two ways to linearize: AUTO and MANUAL: The auto mode requires as many calibration gases as there will be correction points along the curve. The user decides on the number of points, based on the precision required.

The manual mode only requires entering the values for each correction point into the microprocessor via the front panel buttons. Again, the number of points required is determined by the user.

Note: Before performing section 4.8.2 or 4.8.2.3, you must check to ensure that your calibration gases or points are between low end and high end of the range setup. All correction points must be between Zero and Span concentrations. Do not enter Zero and Span points as part of the correction.

4.8.2.2 Manual Mode Linearization

To linearize manually, you must have previous knowledge of the nonlinear thermal-conductivity characteristics of your gases. You enter the value of the differential between the actual concentration and the apparent concentration (analyzer output). Analytical Instruments has tabular data of this type for a large number of gases, which it makes available to customers on request. See Appendix for ordering information. To enter data:

From the *System* Functions Screen—

1. Use <> to select ALGORITHM , and *Enter*.
2. Select and *Enter* SETUP.
3. *Enter* MANUAL from the Calibration Mode Select screen.

```
Dpt INPUT  OUTPUT
0  0.00  0.00
```

The data entry screen resembles the verify screen, but the gas values can be modified and the data-point number cannot. Use the <> keys to toggle between the INPUT and OUTPUT fields. Use the $\Delta \nabla$ keys to set the value for the lowest concentration into the first point. Then press *Enter*.

After each point is entered, the data-point number increments to the next point. Moving from the lowest to the highest concentration, use the $\Delta \nabla$ keys to set the proper values at each point.

```
Dpt INPUT  OUTPUT
1  0.00  0.00
```

Repeat the above procedure for each of the data points you are setting (up to nine points: 0-8). Set the points in unit increments. Do not skip numbers. The linearizer will automatically adjust for the number of points entered.

When you are done, Press *ESCAPE*. The message, Completed. Wait for calculation, appears briefly, and then the main *System* screen returns.

To end the session:

If started with the RS-232, send:

st<enter>

st<enter>

to the analyzer from the computer.

If started through the front panel, turn the instrument off and back on. Press the *Enter* key twice to return to the *Analyze* mode.

4.8.2.3 Auto Mode Linearization

To linearize in the Auto Mode, you must have on hand a separate calibration gas for each of the data points you are going use in your linearization. First, the analyzer is zeroed and spanned as usual. Then, each special span gas, for each of the intermediate calibration points, is flowed, in turn, through the sensor. As each gas flows, the differential value for that intermediate calibration point is entered from the front panel of the analyzer.

Before starting linearization, perform a standard calibration. See section 4.4. To enter data:

From the *System* Functions screen—

1. Use < > to select ALGORITHM , and *Enter*.
2. Select and *Enter* SETUP.
3. *Enter* MANUAL from the Calibration Mode Select screen.

The Auto Linearize Mode data entry screen appears.

```
1.3 % O2 - Air  
Input (0) : 5.94
```

5. Use the $\Delta \nabla$ keys to set the proper value, and *Enter*. Repeat this step for each cal-point number as it appears in the Input (x) parentheses.
6. Repeat step 5 for each of the special calibration gases, from the lowest to the highest concentrations. Press *Escape* when done.

To end the session:

If started with the RS-232, send:

st<enter>
st<enter>

to the analyzer from the computer.

If started through the front panel, turn the instrument off and back on. Press the *Enter* key twice to return to the *Analyze* mode.

4.9 Special Function Setup

4.9.1 Output Signal Reversal

Some applications require a reversal of the output signals in order for the 4-20mA and 0-1 V DC output signals to correspond with the low and high end of the concentration range. For example, if an application involves the analysis of 85% oxygen in a background of argon by measuring the thermal conductivity of the binary gas, the analyzer would normally be set up so that the 100% oxygen (0% argon) concentration would correspond to the zero level (4mA 0 V) of the output signal. Then, 85% oxygen (15% argon) would correspond to 20mA (1 V) in the signal output.

It may be convenient for the user to have the outputs reversed so that the 85-100% oxygen level outputs a 4-20mA (0-1 V) signal respectively. This can be accomplished by reversing the data input to the custom settings. Not all applications will require a reversing function, however, if this is desirable, it must be specified at the time of purchase or alternatively, by substituting a linearizing PC board with the reversal information contained therein. Contact the factory for further information.

4.9.2 Special - Inverting Output

NOTE: If the unit has a range or ranges that specified >0 unit setup for inverting.

The steps are:

1. Press **RANGE** key.
2. Use **LEFT/RIGHT** key to move to the range that is specified as inverting output.
3. Press and hold **DOWN** key for approximate 5 to 7 seconds.

4. Press **ENTER** key.

NOTE: If the inverting has been setup, “i” shall display on the left bottom corner. Otherwise, the left bottom corner display “n”.

If more that one range as specified as inverting output, repeat steps 1 to 4.

4.9.3 Special - Polarity Coding

NOTE: This setup will be identified only when performing *GAS TEST* or calculation. The formula 1 will determine the range(s) is required polarity coding.

If VFD negative with it proper span gas or the calculation is not satisfied, set the S1 accordingly to the table below:

Close S1-5 range 1

Close S1-6 range 2

Close S1-7 range 3

Close S1-8 cal range

Press I/O to restart the system.

4.9.4 Special - Nonlinear Application Gain Preset

NOTE: This section apply during *GAS TEST* routine for the unit that has more than one range install with nonlinear output application.

The steps are as follows:

1. Set unit range to lowest range reading.
2. Using the computer generated settings for the controller, adjust the controller settings for the maximum span gas output.
3. Press **SPAN** key. Select **AUTO** mode and setup the setting to span level. Press **ENTER** key to span.
4. Set range switch to next range.
5. Press **SPAN** key.

6. Press and hold the **RIGHT** key for approximate 5 to 7 seconds.
7. Select **AUTO** and set the reading to span gas level. Press **ENTER** key.

Repeat steps 1 to 7 if more than two ranges need to be setup.

Maintenance

5.1 Routine Maintenance

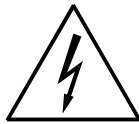

Aside from normal cleaning and checking for leaks at the gas connections, routine maintenance is limited to replacing fuses, and recalibration. For recalibration, see Section 4.4 *Calibration*.

WARNING: SEE WARNINGS ON THE TITLE PAGE OF THIS MANUAL.



5.2 System Self Diagnostic Test

1. Press the *System* button to enter the system mode.
2. Use the <> arrow keys to move to *MORE*, and press *Enter*.
3. Use the <> arrow keys to move to *Self-Test*, and press *Enter*.

The following failure codes apply:

Table 5-1: Self Test Failure Codes

Power

0	OK
1	5 V Failure
2	15 V Failure
3	Both Failed

Analog

0	OK
1	DAC A (0–1 V Concentration)
2	DAC B (0–1 V Range ID)
3	Both Failed

(Continued)

Preamp

- 0 OK
- 1 Zero too high
- 2 Amplifier output doesn't match test input
- 3 Both Failed

Cell

- 0 OK
- 1 Failed (open filament, short to ground, no power.)
- 2 Unbalance (deterioration of filaments, blocked tube)

5.3 VFD Display

NOTE: Vacuum Fluorescent Display is used. It does not need contrast adjustment.

If you cannot read anything on the VFD, especially after first powering up, check the VFD cable is not loose.

5.4 Fuse Replacement

1. Place small screwdriver in notch, and pry cover off, as shown in Figure 5-1.

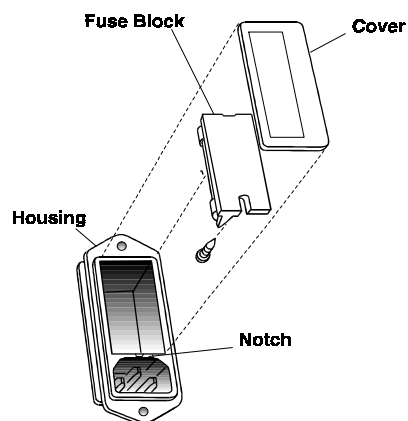

Figure 5-1: Removing Fuse Block from Housing

2. To change between American and European fuses, remove the single retaining screw, flip Fuse Block over 180 degrees, and replace screw.

3. Replace fuse as shown in Figure 5-2.
4. Reassemble Housing as shown in Figure 5-1.

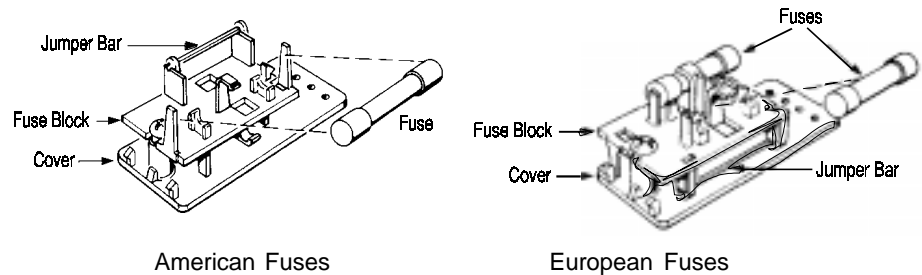

Figure 5-2: Installing Fuses

5.5 Major Internal Components

The Cell Compartment and Front Panel PCBs are accessed by unlatching and swinging open the front panel, as described earlier. The balance of the PCBs are accessed by removing the rear panel retaining screws and sliding out the entire subassembly. See Figure 5-3, below. The major electronic components locations are shown in Figure 5-4 (with Cell Compartment removed for clarity).

WARNING: SEE WARNINGS ON THE TITLE PAGE OF THIS MANUAL.

CAUTION: The front and rear panels and all parts of the instrument case must be tightly closed for CE mark compliance to be in effect.

The 2000A contains the following major components:

- Analysis Section
 - Cell Compartment
 - Cell Block
- Power Supply
- Preamp and Motherboard with Microcontroller
- Display Board and Displays
 - 5 digit LED meter
 - 2 line, 20 character, alphanumeric, VFD display
- Rear Panel Board.

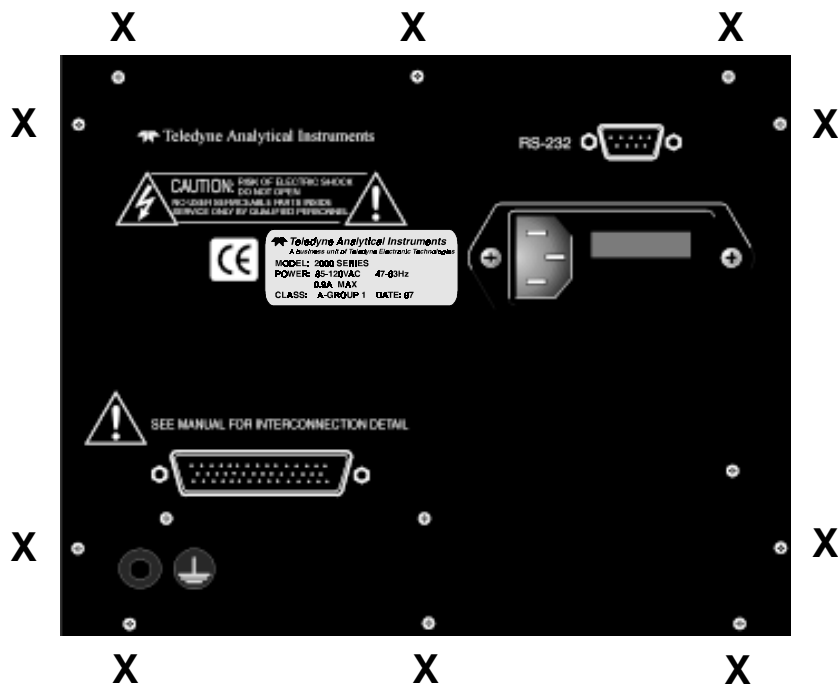

Figure 5-3: Rear Panel Retaining Screws

To detach the rear panel, remove only those screws marked with an X.

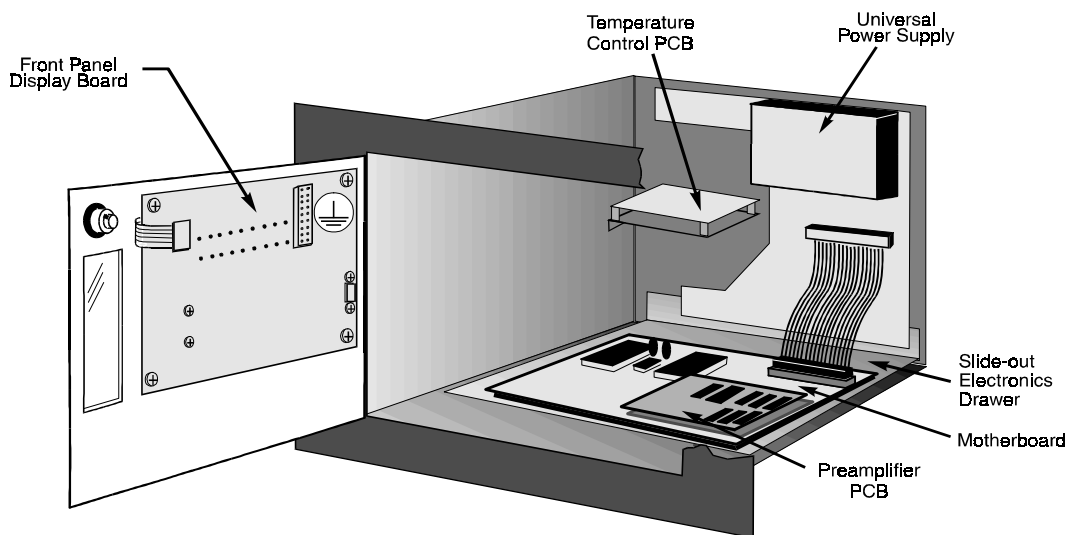

Figure 5-4: Locations of Printed Circuit Board Assemblies

See the drawings in the Drawings section in back of this manual for details.

5.6 Cell, Heater, and/or Thermistor

Replacement

The Thermal Conductivity Cell, with its Heater and Thermistor, is mounted inside the insulated cell compartment, just behind the analyzer's front panel access door. To remove the one of these components, you must first slide the entire Cell Compartment out of the analyzer through the front panel access door as described in the procedure below. Figure 5-5 identifies the five screws that must be removed in order to remove the Cell Compartment.

5.6.1 Removing the Cell Compartment

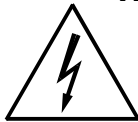

WARNING: IF THE MODEL 2000 ANALYZER HAS BEEN USED WITH TOXIC GASES, FLUSH IT THOROUGHLY BEFORE PERFORMING THIS PROCEDURE.

WARNING: DISCONNECT ALL POWER TO THE MODEL 2000 BEFORE PERFORMING THIS PROCEDURE. FAILURE TO DO SO, MAY CAUSE ELECTRIC SHOCK.

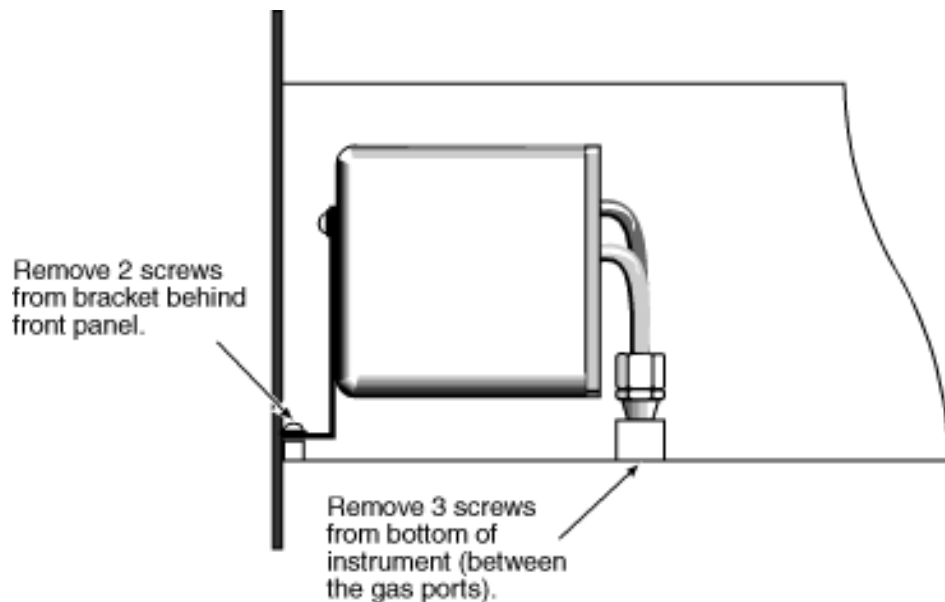

Figure 5-5: Location of Cell Compartment Retaining Screws

To remove the Cell Compartment:

- Disconnect gas and electrical connections to the analyzer.

- b. Remove analyzer from its mounting, and remove gas fittings from the gas ports on the bottom of the analyzer, so that nothing projects from the ports.
- c. Remove the Cell Compartment retaining screws identified in Figure 5-5. You will have to unlatch and swing open the front panel door to remove the front screws.
- d. Carefully pull the Cell Compartment out through the front of the analyzer. There is enough length to the cell's electrical wiring to allow this.
- e. After replacing the necessary component and reassembling the Cell Compartment, Replace the Compartment by reversing the above procedure, steps a through d.

5.6.2 Removing and Replacing the Cell Block

- a. Refer to Figure 5-6, which illustrates removal of the Cell Block from the Cell Compartment. Exploded view is as seen from the top of the Cell Block.

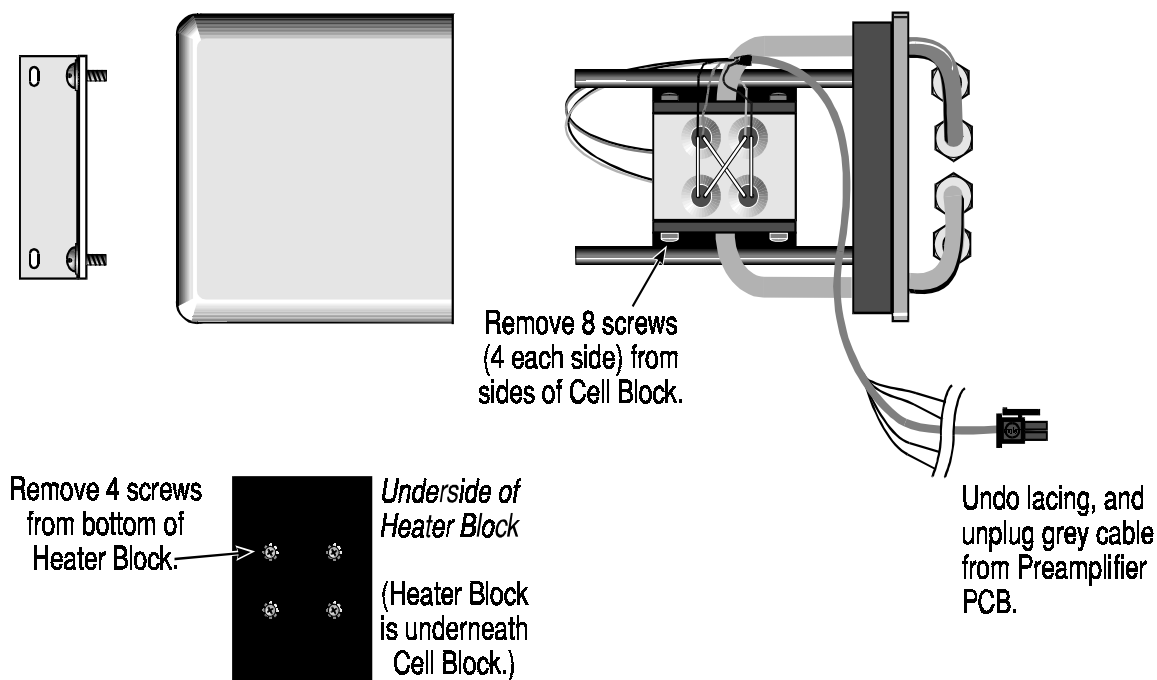

Figure 5-6: Removal of Cell from Cell Housing

- b. Remove the two screws holding the front mounting bracket—they also hold the Cell Block Cover to the Cell Block—and then pull off the cover.

- c. Turn the uncovered Cell Block assembly over so that the bottom faces you. The black rectangular block with four screws is the Heater Block. Separate the Heater Block and Insulator from the Cell Block by removing the four screws. Leave the Heater Block electrical connections connected.
- d. Remove the four screws from each of the black plates that hold the Cell. The Cell is sandwiched between the plates. You should now be able to slide the Cell free.
- e. Leave the electrical connections connected at the Cell. Unlace the cabling, and unplug the grey Cell cable at the Preamplifier PCB connector, J3. (See Figure 5-4, and/or drawings at the rear of this manual.) The Preamplifier PCB can be more easily accessed by removing the analyzer's rear panel. (See Section 5.5.)
- f. Replace the cell by reversing the above procedure, steps a through e.

5.6.3 Removing the Heater and/or Thermocouple

- a. Refer to Figure 5-7, which illustrates removal of the Thermistor and/or Heater from the Cell Compartment. Exploded view is as seen from the bottom of the Cell Block.

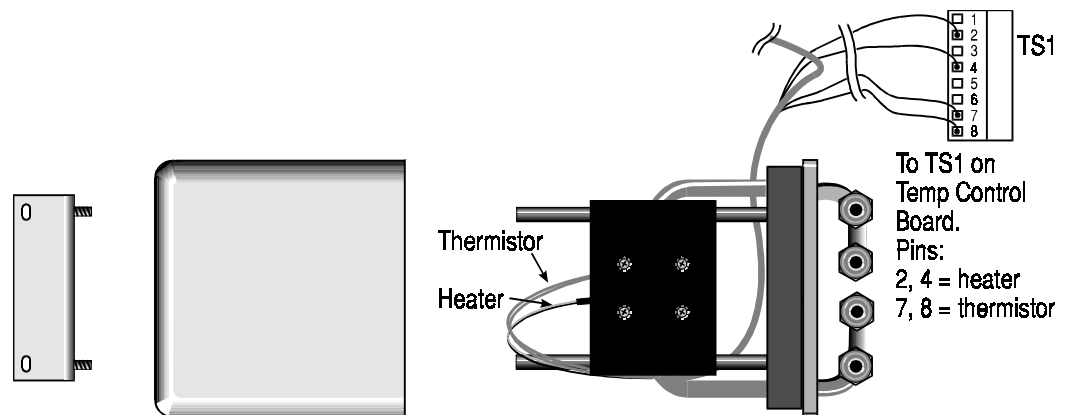

Figure 5-7: Removing the Heater and/or Thermocouple

- b. Remove the two screws holding the front mounting bracket—they also hold the Cell Block Cover to the Cell Block—and then pull off the cover.
- c. Turn the uncovered Cell Block assembly over so that the bottom faces you. The black rectangular block with four screws is the Heater Block.

-
- d. The Heater is fastened to the Heater Block by a set screw as well as the silicone sealing compound. The Thermistor is fastened only by the silicone sealer.
 - (1) To remove the Heater, use a $1/16$ " Allen wrench to loosen the Thermistor set screw. Then, grasp BOTH Heater wires firmly, and pull the Heater slowly out of the Heater Block, breaking the silicone seal. Do not allow any foreign matter to enter the empty duct.
 - (2) To remove the Thermistor, grasp BOTH Thermistor wires firmly, and pull the Thermistor slowly out of the Heater Block, breaking the silicone seal. Do not allow any foreign matter to enter the empty duct.
 - e. Undo the cable lacing and separate the Heater/Thermistor wires. Then, disconnect the wires from TS1 on the Temperature Control Board. (See Figures 5-4 and 5-7.)

5.6.4 Replacing the Heater and/or Thermocouple

- a. To replace the Heater and/or Thermocouple, coat the new element with silicone sealing compound, and insert it into the duct.

CAUTION: *The larger duct is for the Heater element, and the smaller duct is for the Thermocouple.*

- b. Enough sealing compound should be on the element to spill over and seal around the wire where it enters the duct. Smooth the outer seal and remove any excess.
- c. Reassemble the Cell Compartment by reversing the procedure in section 5.6.3. Then relace the cabling.
- d. Reinstall the Assembled Cell Compartment by reversing the procedure in section 5.6.1. Then reconnect the wires to TS1 on the Temperature Control board.

5.7 Cleaning

If instrument is unmounted at time of cleaning, disconnect the instrument from the power source. Close and latch the front-panel access door. Clean outside surfaces with a soft cloth dampened slightly with plain clean water. Do not use any harsh solvents such as paint thinner or benzene.

For mounted instruments, DO NOT wipe the front panel while the instrument is controlling your process. Clean the front panel as prescribed in the above paragraph.

5.8 Phone Numbers

Customer Service: (626) 934-1673

Environmental Health and Safety: (626) 961-9221, Extension 230

Fax: (626) 961-2538

TWX: (910) 584-1887 TDYANYL COID

EMERGENCY ONLY: (24-hour pager) 1-800-759-7243
PIN # 1858192

Appendix

A-1 Specifications

Ranges: Three ranges plus a cal range, field selectable within limits (application dependent) and Auto Ranging

Display: 2 line by 20 alphanumeric VFD accompanied by 5 digit LED display

Accuracy: $\pm 1\%$ of full scale for most binary mixtures at constant temperature
 $\pm 5\%$ of full scale over operating temperature range once temperature equilibrium has been reached

Response Time: 90% in less than 50 seconds

System Operating

Temperature: 32°F to 122°F (0 - 50°C)

Sensor Type: Standard TC cell (4-filament detector)

Signal Output: Two 0-1 VDC (concentration and range ID)
Two 4-20 mADC isolated (concentration and range ID)

Alarm: Two fully programmable concentration alarm set points and corresponding Form C, 3 amp contacts.

One system failure alarm contact to detect power, calibration, zero / span and sensor failure.

System Power**Requirements:** 110 VAC, 50-60Hz**Dimensions:** 7.5”H x 10.8 “w X 13.7”D**Cell Material:** Nickel plated brass block with nickel alloy filaments and stainless steel plates**O/P Interface:** Full duplex RS-232, implement a subset of Tracs Command**Mounting:****Standard:** General purpose flush panel mounting**Options:** General purpose rack mounted to contain either one or two in a 19” rack mountable plate**Relative Humidity:** Up to 99%**Altitude:** 1,609 m

* *Other configurations, including a totally explosion-proof, are available*

A-2 Recommended 2-Year Spare Parts List

<i>Qty</i>	<i>Part Number</i>	<i>Description</i>
1	C65507A	Back Panel Board
1	C62371A	Front Panel Board
1	C65098	Preamplifier Board
1	C62365D	Main Computer Board
1	C69535A	Temp Control Board for 110 VAC
1	C69535B	Temp Control Board for 220 VAC
1*	F9	Fuse, 1 A, 250 V, 3AG, Slow Blow, (US)
2*	F1275	Fuse, 1 A, 250 V, 5 × 20 mm, T—Slow Blow, (European)
1	CP1798	Plug, 50 pin D-sub Connector
1	CP1802	Shielded Cable Clamp
50	CP1799	Solder Cup Contact, for CP1798

*Select set of fuses accordingly

Note: Orders for replacement parts should include the part number (if available) and the model and serial number of the instrument for which the parts are intended.

Orders should be sent to:

TELEDYNE Analytical Instruments

16830 Chestnut Street
City of Industry, CA 91749-1580

Phone (626) 934-1500, Fax (626) 961-2538
TWX (910) 584-1887 TDYANYL COID

Web: www.teledyne-ai.com

or your local representative.

A-3 Drawing List

C-66922:	Wiring Diagram / Interconnect Drawing
D-67956	Piping Diagram
D-67915	Outline Diagram

