

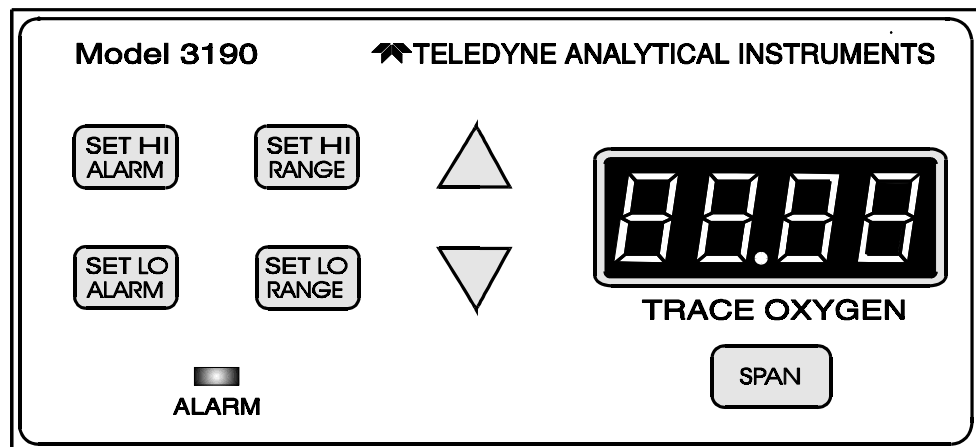

OPERATING INSTRUCTIONS
FOR
Model 3190 Series
Trace Oxygen Analyzer



 **DANGER** 

HIGHLY TOXIC AND/OR FLAMMABLE LIQUIDS OR GASES MAY BE PRESENT IN THIS MONITORING SYSTEM.
PERSONAL PROTECTIVE EQUIPMENT MAY BE REQUIRED WHEN SERVICING THIS SYSTEM.
HAZARDOUS VOLTAGES EXIST ON CERTAIN COMPONENTS INTERNALLY WHICH MAY PERSIST FOR A TIME EVEN AFTER THE POWER IS TURNED OFF AND DISCONNECTED.
ONLY AUTHORIZED PERSONNEL SHOULD CONDUCT MAINTENANCE AND/OR SERVICING. BEFORE CONDUCTING ANY MAINTENANCE OR SERVICING CONSULT WITH AUTHORIZED SUPERVISOR/MANAGER.

P/N M64641
06/21/2000
ECO # 00-0221

Copyright © 1999 Teledyne Analytical Instruments

All Rights Reserved. No part of this manual may be reproduced, transmitted, transcribed, stored in a retrieval system, or translated into any other language or computer language in whole or in part, in any form or by any means, whether it be electronic, mechanical, magnetic, optical, manual, or otherwise, without the prior written consent of Teledyne Analytical Instruments, 16830 Chestnut Street, City of Industry, CA 91749-1580.

Warranty

This equipment is sold subject to the mutual agreement that it is warranted by us free from defects of material and of construction, and that our liability shall be limited to replacing or repairing at our factory (without charge, except for transportation), or at customer plant at our option, any material or construction in which defects become apparent within one year from the date of shipment, except in cases where quotations or acknowledgements provide for a shorter period. Components manufactured by others bear the warranty of their manufacturer. This warranty does not cover defects caused by wear, accident, misuse, neglect or repairs other than those performed by Teledyne or an authorized service center. We assume no liability for direct or indirect damages of any kind and the purchaser by the acceptance of the equipment will assume all liability for any damage which may result from its use or misuse.

We reserve the right to employ any suitable material in the manufacture of our apparatus, and to make any alterations in the dimensions, shape or weight of any parts, in so far as such alterations do not adversely affect our warranty.

Important Notice

This instrument provides measurement readings to its user, and serves as a tool by which valuable data can be gathered. The information provided by the instrument may assist the user in eliminating potential hazards caused by his process; however, it is essential that all personnel involved in the use of the instrument or its interface, with the process being measured, be properly trained in the process itself, as well as all instrumentation related to it.

The safety of personnel is ultimately the responsibility of those who control process conditions. While this instrument may be able to provide early warning of imminent danger, it has no control over process conditions, and it can be misused. In particular, any alarm or control systems installed must be tested and understood, both as to how they operate and as to how they can be defeated. Any safeguards required such as locks, labels, or redundancy, must be provided by the user or specifically requested of Teledyne at the time the order is placed.

Therefore, the purchaser must be aware of the hazardous process conditions. The purchaser is responsible for the training of personnel, for providing hazard warning methods and instrumentation per the appropriate standards, and for ensuring that hazard warning devices and instrumentation are maintained and operated properly.

Teledyne Analytical Instruments (TAI), the manufacturer of this instrument, cannot accept responsibility for conditions beyond its knowledge and control. No statement expressed or implied by this document or any information disseminated by the manufacturer or its agents, is to be construed as a warranty of adequate safety control under the user's process conditions.

Specific Model Information

The instrument for which this manual was supplied may incorporate one or more options not supplied in the standard instrument. Commonly available options are listed below, with check boxes. Any that are incorporated in the instrument for which this manual is supplied are indicated by a check mark in the box.

Instrument Serial Number: _____

Options Included in the Instrument with the Above Serial Number:

- Class A-2C Micro-Fuel Cell:** For 0-100% CO₂ background and General Purpose (range 0-10 ppm O₂ minimum).
- Class B-2C Micro-Fuel Cell:** For General Purpose and high hydrogen or helium backgrounds (range 0-10 ppm O₂ minimum).
- Class Z-2C Micro-Fuel Cell:** For faster recovery after air calibration (range 0-200 ppm O₂ minimum).

Class B-2C is the standard cell provided.

Contents

Introduction

1.1 Overview	1-1
1.2 Main Features of the Analyzer	1-1
1.3 Front Panel Description	1-2
1.4 Rear Panel Description	1-3

Operational Theory

2.1 Introduction	2-1
2.2 Micro-Fuel Cell Sensor	2-1
2.2.1 Principles of Operation	2-1
2.2.2 Anatomy of a Micro-Fuel Cell	2-2
2.2.3 Electrochemical Reactions	2-3
2.2.4 The Effect of Pressure	2-4
2.2.5 Calibration Characteristics	2-4
2.3 Electronics	2-5
2.3.1 General	2-5
2.3.2 Signal Processing	2-5

Installation

3.1 Unpacking the Analyzer	3-1
3.2 Location and Mounting	3-2
3.2.1 Control Unit Installation	3-2
3.2.2 External Probe Installation	3-2
3.2.3 Installing the Micro-Fuel Cell	3-3
3.3 Electrical Connections	3-3
3.4 Gas Connections	3-7
3.5 Installation Checklist	3-7

Operation

4.1 Introduction	4-1
4.2 Using the Function and Data Entry Buttons	4-2
4.3 Setting the Analysis Ranges	4-2
4.3.1 HI Range	4-3
4.3.2 LO Range	4-3
4.3.3 Settle Mode	4-3

4.4	Setting the Alarm Setpoints	4-3
4.4.1	HI Alarm	4-3
4.4.2	LO Alarm	4-3
4.4.3	Sensor Fail Alarm	4-4
4.5	Selecting a Fixed Range or Autoranging	4-4
4.6	Calibration	4-4
4.7	Displaying Percent & PPM on the LED Display	4-5
4.8	"SetL" mode in the LED display	4-6

Maintenance

5.1	Replacing the Fuse	5-1
5.1.1	AC Powered Units	5-1
5.1.2	DC Powered Units	5-2
5.2	Sensor Installation or Replacement	5-2
5.2.1	When to Replace a Sensor	5-2
5.2.2	Ordering and Handling of Spare Sensors	5-3
5.2.3	Removing the Micro-Fuel Cell	5-3
5.2.4	Installing a Micro-Fuel Cell	5-4
5.2.5	Cell Warranty Conditions	5-5

Appendix

A.1	Specifications	A-1
A.2	Spare Parts List	A-2
A.3	Drawing List	A-3
A.4	Miscellaneous	A-3
A.5	Material Safety Data Sheet	A-4



Introduction

1.1 Overview

The Teledyne Analytical Instruments (TAI) Model 3190 is a microprocessor-based trace oxygen analyzer for real-time measurement of trace amounts of oxygen in inert gases, or in a wide variety of gas mixtures. It features simple operation, fast response, and a compact, rugged construction. Typical applications of the Model 3190 are monitoring nitrogen generators and inert gas blanketing applications.

1.2 Main Features of the Analyzer

The main features of the analyzer include:

- High resolution, accurate readings of oxygen content from 0-10 ppm through 0-25 %. Large, bright, light-emitting-diode meter readout.
- Simple pushbutton controls.
- Nylon cell holder.
- Advanced Micro-Fuel Cell, for trace analysis, has a six (6) months warranty and expected lifetime.
- Unaffected by oxidizable gases.
- Fast response and recovery time.
- Microprocessor based electronics: 8-bit CMOS microprocessor with on-board RAM and 16 kB ROM.
- Two user selectable ranges (from 0-10 ppm through 0-9,999 ppm) allow best match to users process and equipment.
- Air-calibration range for convenient spanning at 20.9 %.
- Operator can select Autoranging, which allows the analyzer to automatically select the proper preset range for a given measurement, or he can lock the analyzer onto a single range.

- Two concentration alarms with adjustable setpoints.
- Sensor failure alarm.
- RS-232 serial digital port for output of concentration and range data to a computer, terminal, or other digital device.
- Three analog outputs: two for measurement (0–10 V dc, and negative ground 4–20 mA dc) and one for range identification (0–10 V dc).
- Compact and rugged Control Unit with flush-panel case. Designed for indoor use. Front panel NEMA-4 rated.
- External Probe can be located six feet or more away, depending on the existing electromagnetic noise level.

1.3 Front Panel Description

All controls and displays except the power switch are accessible from the front panel. See Figure 1-1. The front panel has seven pushbutton membrane switches, a digital meter, and an alarm indicator LED for operating the analyzer. These features are described briefly here and in greater detail in Chapter 4, *Operation*.

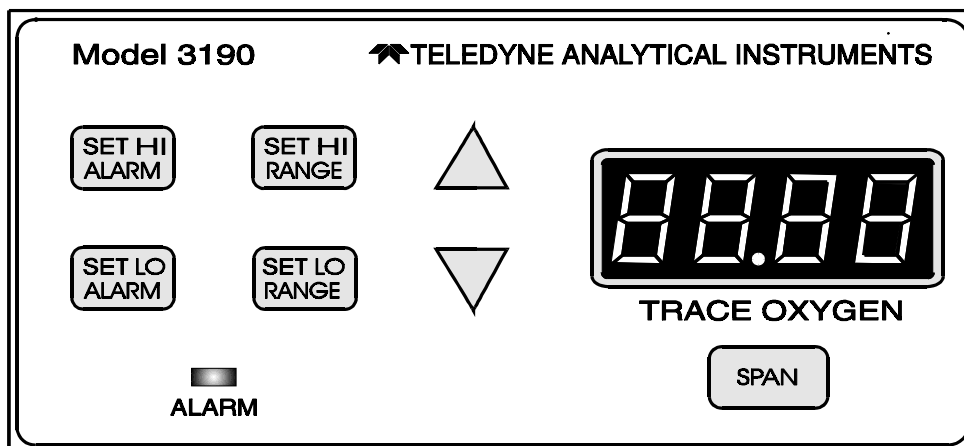

Figure 1-1: Front Panel

Function Keys: Seven pushbutton membrane switches are used to select the function performed by the analyzer:

- **Set HI Alarm** Set the concentration ABOVE which an alarm activates.
- **Set LO Alarm** Set the concentration BELOW which an alarm activates.
- **Set HI Range** Set the high analysis range for the instrument (up to 0-9999 ppm).
- **Set LO Range** Set the low analysis range for the instrument (down to 0-10 ppm).
- **Span** Span calibrate the analyzer.

Data Entry Keys: Two pushbutton membrane switches are used to manually change measurement parameters of the instrument as they are displayed on the LED meter readout:

- **Up Arrow** Increment values of parameters upwards as they are displayed on the LED readout.
- **Down Arrow** Increment values of parameters downwards as they are displayed on the LED readout.

Digital LED Readout: The digital display is a LED device that produces large, bright, 7-segment numbers that are legible in any lighting environment. It has two functions:

- **Meter Readout:** As the meter readout, it displays the oxygen concentration currently being measured.
- **Measurement Parameters Readout:** It also displays user-definable alarm setpoints, ranges, and span calibration point when they are being checked or changed.

1.4 Rear Panel Description

The rear panel contains the electrical input and output connectors. Separate rear panel illustrations are shown in Figure 1-2 for the AC and DC powered versions of the instrument. The connectors are described briefly here and in detail in the *Installation* chapter of this manual.

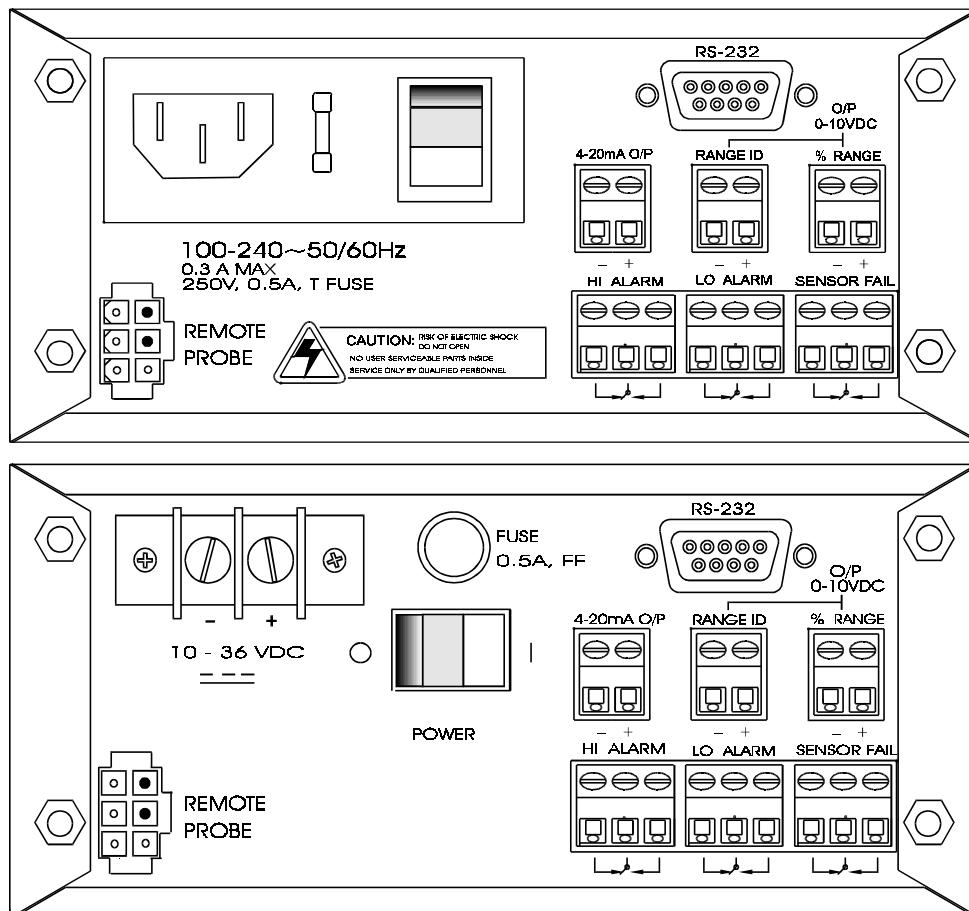

Figure 1-2 Rear Panel (AC and DC versions)

- Power Connection**

AC version: 100–240 V ac, at 50/60 Hz. The connector housing includes the fuse holder and the power switch.

DC version: Requires between 10 and 36 V dc.

Fuse Holder: Replacing the fuse is described in Chapter 5, *Maintenance*.

I/O Power Switch: Turns the instrument power ON (1) or OFF (0).
- Analog Outputs**

0–10 V dc concentration output.

0–10 V dc range ID (or optional overrange) output.

4–20 mA dc concentration output, negative ground.

- **Alarm Connections** HI Alarm, LO Alarm, and Sensor Failure Alarm connections.
- **RS-232 Port** Serial digital output of concentration and range signals.
- **External Probe** Connects to the Remote Probe or remote Analysis Unit.

Operational Theory

2.1 Introduction

The analyzer is composed of two subsystems:

1. Analysis Unit with Micro-Fuel Cell Sensor
2. Control Unit with Signal Processing, Display and Controls

The Analysis Unit is designed to accept the sample gas and direct it to the sensitive surface of the Micro-Fuel Cell sensor. The Micro-Fuel Cell is an electrochemical galvanic device that translates the amount of oxygen present in the sample into an electrical current.

The Control Unit processes the sensor output and translates it into electrical concentration, range, and alarm outputs, and a trace oxygen meter readout. It contains a microcontroller that manages all signal processing, input/output, and display functions for the analyzer.

2.2 Micro-Fuel Cell Sensor

2.2.1 Principles of Operation

The oxygen sensor used in the Model 3190 is a Micro-Fuel Cell designed and manufactured by TAI. It is a sealed, disposable electrochemical transducer.

The active components of the Micro-Fuel Cell are a cathode, an anode, and the 15 % aqueous KOH electrolyte in which they are immersed. The cell converts the energy from a chemical reaction into an electrical current through an external electrical circuit. Its action is similar to that of a battery.

There is, however, an important difference in the operation of a battery as compared to the Micro-Fuel Cell: In the battery, all reactants are

stored within the cell, whereas in the Micro-Fuel Cell, one of the reactants (oxygen) comes from outside the device as a constituent of the sample gas being analyzed. The Micro-Fuel Cell is therefore a hybrid between a battery and a true fuel cell. (All of the reactants are stored externally in a true fuel cell.)

2.2.2 Anatomy of a Micro-Fuel Cell

The Micro-Fuel Cell is a cylinder only 1¼ inches in diameter and 1 inch thick. It is made of extremely inert plastic, which can be placed confidently in practically any environment or sample stream. It is effectively sealed, although one end is permeable to oxygen in the sample gas. The other end of the cell is a contact plate consisting of two concentric foil rings. The rings mate with spring-loaded contacts in the sensor block assembly and provide the electrical connection to the rest of the analyzer. Figure 2-1 illustrates the external features.

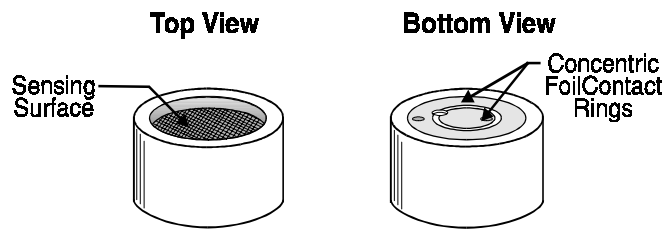

Figure 2-1: Micro-Fuel Cell

Refer to Figure 2-2, *Cross Section of a Micro-Fuel Cell*, which illustrates the following internal description.

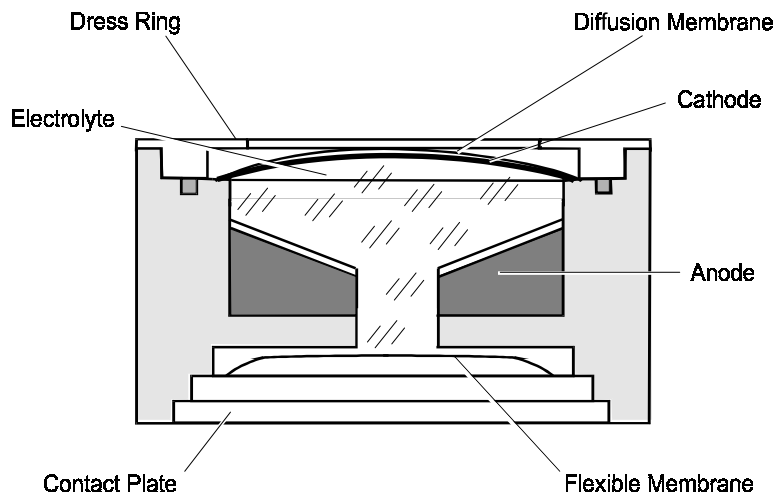

Figure 2-2. Cross Section of a Micro-Fuel Cell (simplified)

At the top end of the cell is a diffusion membrane of Teflon, whose thickness is very accurately controlled. Beneath the diffusion membrane lies the oxygen sensing element—the cathode—with a surface area almost 4 cm². The cathode has many perforations to ensure sufficient wetting of the upper surface with electrolyte, and it is plated with an inert metal.

The anode structure is below the cathode. It is made of lead and has a proprietary design which is meant to maximize the amount of metal available for chemical reaction.

At the rear of the cell, just below the anode structure, is a flexible membrane designed to accommodate the internal volume changes that occur throughout the life of the cell. This flexibility assures that the sensing membrane remains in its proper position, keeping the electrical output constant.

The entire space between the diffusion membrane, above the cathode, and the flexible rear membrane, beneath the anode, is filled with electrolyte. Cathode and anode are submerged in this common pool. They each have a conductor connecting them to one of the external contact rings on the contact plate, which is on the bottom of the cell.

2.2.3 Electrochemical Reactions

The sample gas diffuses through the Teflon membrane. Any oxygen in the sample gas is reduced on the surface of the cathode by the following HALF REACTION:



(Four electrons combine with one oxygen molecule—in the presence of water from the electrolyte—to produce four hydroxyl ions.)

When the oxygen is reduced at the cathode, lead is simultaneously oxidized at the anode by the following HALF REACTION:

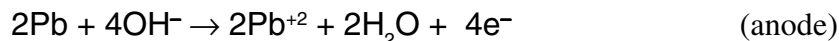

(Two electrons are transferred for each atom of lead that is oxidized. TWO ANODE REACTIONS balance one cathode reaction to transfer four electrons.)

The electrons released at the surface of the anode flow to the cathode surface when an external electrical path is provided. The current is proportional to the amount of oxygen reaching the cathode. It is measured and used to determine the oxygen concentration in the gas mixture.

The overall reaction for the fuel cell is the SUM of the half reactions above, or:

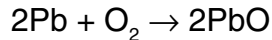

(These reactions will hold as long as no gaseous components capable of oxidizing lead—such as iodine, bromine, chlorine and fluorine—are present in the sample. The only likely components are the halogens.)

The output of the fuel cell is limited by (1) the amount of oxygen in the cell at the time and (2) the amount of stored anode material. In the absence of oxygen, no current is generated.

2.2.4 The Effect of Pressure

In order to state the amount of oxygen present in the sample as a specific portion of the gas mixture, it is necessary that the sample diffuse into the cell under constant pressure.

If the total pressure increases, the rate that oxygen reaches the cathode through the diffusing membrane will also increase. The electron transfer, and therefore the external current, will increase, even though the oxygen concentration of the sample has not changed. It is therefore important that the sample pressure at the fuel cell (Usually vent pressure) remain relatively constant between calibrations.

2.2.5 Calibration Characteristics

Given that the total pressure of the sample gas on the surface of the Micro-Fuel Cell input is constant, a convenient characteristic of the cell is that the current produced in an external circuit of constant impedance is directly proportional to the rate at which oxygen molecules reach the cathode, and this rate is directly proportional to the concentration of oxygen in the gaseous mixture. In other words it has a linear characteristic curve, as shown in Figure 2-2. Measuring circuits do not have to compensate for nonlinearities.

Also, since there is zero output in the absence oxygen, the characteristic curve has an absolute zero. The cell itself does not need to be zeroed.

As the cell reaches the end of its useful life, the slope seen in Figure 2-2 decreases. In the Model 3190, the slope is monitored. If the inverse of the slope:

$$\text{Span Value (ppm) / Cell Output (nA)}$$

is over 4.447 ppm/nA, a sensor failure alarm is triggered, indicating that the cell should be replaced.

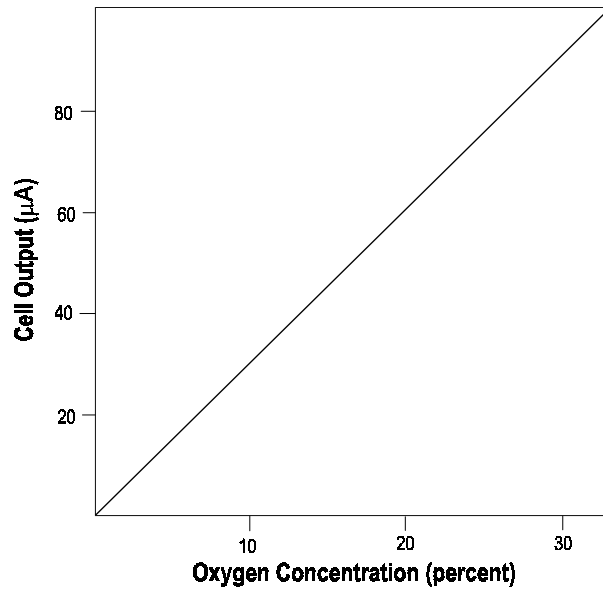

Figure 2-2. Characteristic Input/Output Curve for a Micro-Fuel Cell

2.3 Electronics

2.3.1 General

The signal processing uses an Intel® microcontroller with on-board RAM and ROM to control all signal processing, input/output, and display functions for the analyzer. System power is supplied from a universal power supply module designed to be compatible with most international power sources.

The power supply circuitry is on the Power Supply PCB, which is mounted vertically, just behind the rear panel of the Control Unit.

The signal processing electronics including the temperature compensated amplifier, microcontroller, analog to digital, and digital to analog converters are located on the Main PCB, which is mounted vertically, just behind the front panel of the Control Unit.

2.3.2 Signal Processing

Figure 2-3 is a block diagram of the signal processing electronics described below.

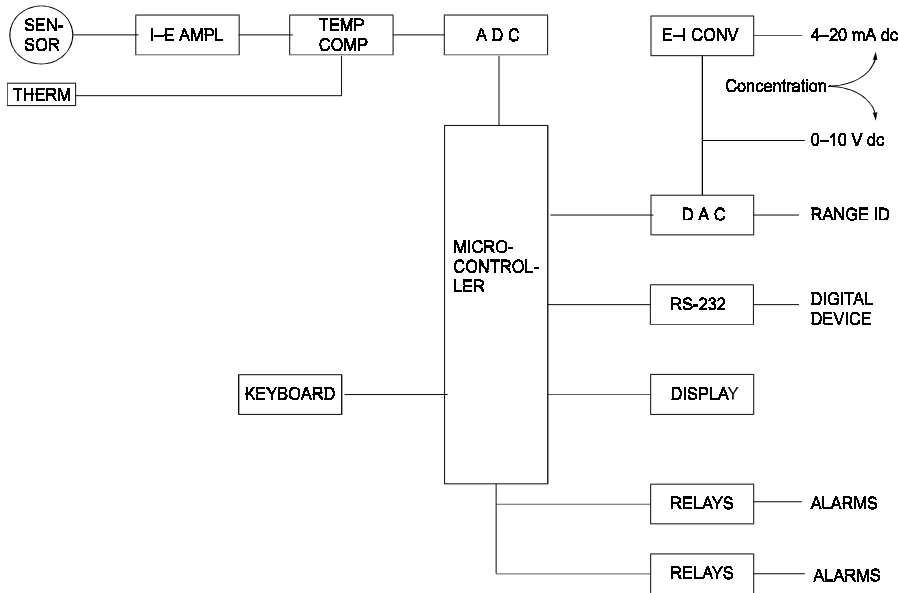

Figure 2-3: Block Diagram of the Signal Processing Electronics

In the presence of oxygen the cell generates a current. A current to voltage amplifier (I-E AMPL) converts this current to a voltage.

The second stage amplifier (TEMP COMP) supplies temperature compensation for the oxygen sensor output. The temperature compensation amplifier incorporates a thermistor (THERM) that is physically located in the cell block. The thermistor is a temperature dependent resistance that changes the gain of the amplifier in proportion to the temperature changes in the block. This change is inversely proportional to the change in the cell output due to the temperature changes. As a result there is negligible net change in the signal due to temperature changes once the sensor comes to equilibrium. See *Specifications* in the Appendix.

The output from the temperature compensation amplifier is sent to an analog to digital converter (ADC), and the resulting digital concentration signal is sent to the microcontroller.

The digital concentration signal along with input from the front panel buttons (KEYBOARD) is processed by the microcontroller, and appropriate output signals are directed to the display, alarm relays, and RS-232 output. The same digital information is also sent to a 12-bit digital to analog converter (DAC) that produces the 0-10 V dc analog concentration signal and the 0-10 V dc analog range ID output. A current to voltage converter (E-I CONV) produces the 4-20 mA dc concentration signal.

Installation

*Overvoltage
Category II*

Installation of the analyzer includes:

1. Unpacking the system.
2. Mounting the Control Unit, External Sample Block, and Micro-Fuel Cell sensor.
3. Making the electrical connections.
5. Making the gas connections.
6. Testing the installation.

CAUTIONS: *Read this chapter in its entirety before installing the units.*

The Model 3190 is for or indoor use only.

The sample must be free of entrained solids or water. However, a high humidity sample is ideal, since it will prevent water loss from the cell electrolyte.

The Micro-Fuel Cell sensor electrolyte is caustic. Do not attempt to open it. Leaking or exhausted cells should be disposed of in accordance with local regulations. Refer to the Material Safety Data Sheet in the Appendix.

Any damage or scarring of the delicate permeable membrane on the sensing end of the cell will require cell replacement. Prevent contact with membrane by any solid object.



3.1 Unpacking the Analyzer

As soon as you receive the instrument, carefully unpack and inspect Control Unit, External Probe, and any included accessories for damage. Immediately report any damage to the shipping agent. The analyzer is

shipped with all the materials you need to install and prepare the system for operation.

CAUTION: *Do not disturb the integrity of the cell package until the cell is to be used immediately. If the cell package is punctured prematurely and air is permitted to enter, cell life will be shortened.*

3.2 Location and Mounting

3.2.1 Control Unit Installation

The 3190 Control Unit is designed to be panel-mounted in a general purpose, indoor area, away from moisture and the elements. The unit should be installed at viewing level in a sheltered area.

CAUTION: *For the DC powered version, the control unit chassis must be isolated from the input power ground.*

Refer to the Outline Diagram C-64772 for the physical dimensions of the analyzer.

3.2.2 External Probe Installation

The External Probe can be installed in the process any reasonable distance from the Control Unit. The nominal maximum is 6 ft, but the distance can be more, depending on the level of electromagnetic noise in the operating environment.

The standard Model 3190 includes the External Probe unit depicted in the Final Assembly, Dwg C-64641, and the Analysis Unit (probe) Outline, Dwg B-59610. Dimensions are also given in *Specifications* in the Appendix.

For special applications, the type of External Probe unit supplied may vary depending on the specific process. With these systems, specific installation and interconnect information is given in a separate probe manual or in an addendum to this manual depending on the model External Probe used. The addendum will reference the specific Outline and Interconnection Drawings in the Drawings section of this manual, and provides any other appropriate information.

For special applications the Micro-Fuel Cell may also be of a different type than the standard A-2C, B-2C or Z-2C unit. If this is the case, the pertinent cell specifications will be given in the addendum.



3.2.3 Installing the Micro-Fuel Cell / Cell Block Orientation

A Micro-Fuel Cell is included as a separate item. It must be installed prior to instrument use.

Also, once it is expended, or if the instrument has been idle for a lengthy period, the Micro-Fuel Cell will need to be replaced.

Important Installation Note!

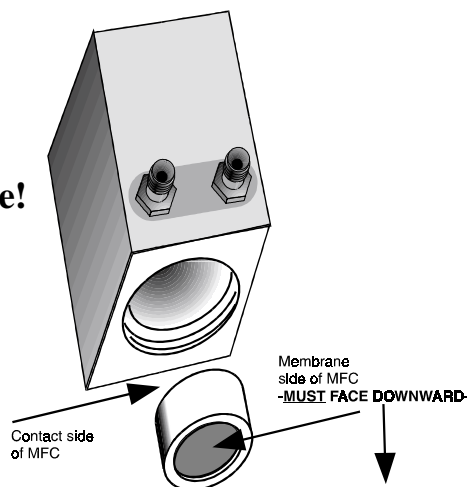

During the Installation and/or Replacement of the MFC, **Membrane** surface **MUST ALWAYS FACE DOWNWARD**, and the Contact side of the Membrane, **MUST** be placed **FIRST** into Analysis Unit.

The reason for proper Installation/Replacement is, if any bubble that develops as the electrolyte dries out will be directed by the gravity away from the membrane.

To install or replace the Micro-Fuel Cell, follow the procedures in Chapter 5, *Maintenance*.

3.3 Electrical Connections

Figure 3-1 shows the two alternate Model 3190 rear panels. The first illustration shows the AC powered version, and the second illustration shows the DC powered version. The difference between them is the power connections. Both versions have identical connections for the External Probe, the alarms, and for the digital and analog concentration outputs. For detailed pinouts, see the wiring/interconnection drawings in the Drawings section at the rear of this manual.

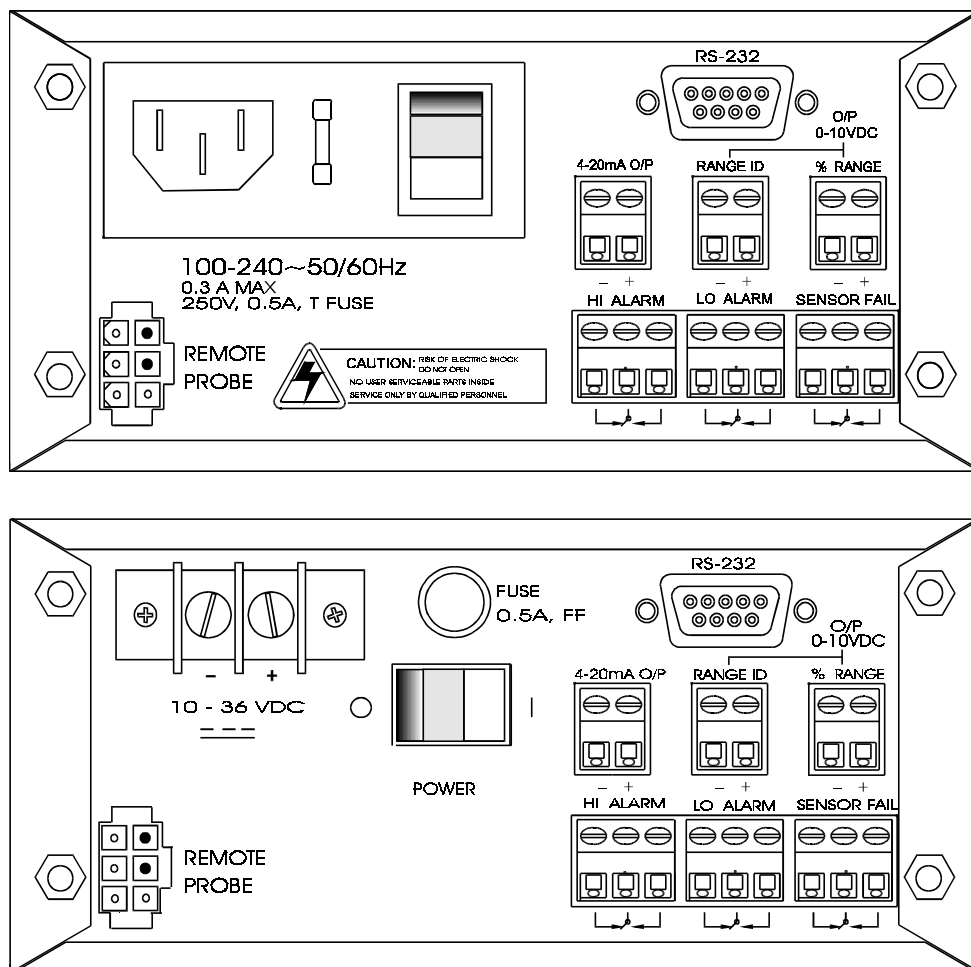

Figure 3-1 Rear Panel Electrical Connectors for AC and DC Units

Primary Input Power (AC version): The power cord receptacle, fuse block and Power switch are located in the same assembly. A 6-foot, standard AC power cord is supplied with the Control Unit. Insert the female plug end of the power cord into the power cord receptacle.

The universal power supply allows direct connection to any 100-240 V ac, 50/60 Hz power source. The fuse block, to the right of the power cord receptacle, accepts a 5 × 20 mm, 0.5 A, time-lag (T) fuse. (See *Fuse Replacement* in chapter 5, *Maintenance*.)

The Power switch is located on the right-hand end of the power source input receptacle assembly.

Primary Input Power (DC version): The 10–36 V dc power is connected via the + and – terminals in the upper left corner of the panel. The

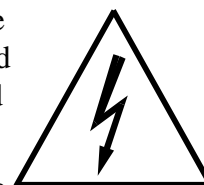

fuse receptacle, to the right of the power terminal strip, holds a 0.5 A, very quick acting fuse. (See *Fuse Replacement* in chapter 5, *Maintenance*.)

The Power switch is located below the fuse receptacle.

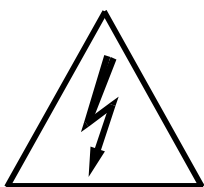

WARNING: INSERT THE STRIPPED TIPS OF WIRES ENTIRELY INTO THE TERMINAL BLOCKS. DO NOT LEAVE EXPOSED WIRE OUTSIDE OF THE HOLES IN THE BLOCKS.

CAUTION: The control unit chassis must be isolated from the grounding system of the DC input power.

Analog Outputs: There are three DC output signal connectors with screw terminals on the panel. There are two wires per output with the polarity noted. See Figure 3-3. The outputs are:

0–10 V concentration: Voltage rises with increasing oxygen concentration, from 0 V at 0 oxygen content to 10 V at full scale oxygen content. (Full scale = 100 % of programmed range.)

0–10 V Range ID: 03.33 V = Low Range, 06.66 V = High Range, 10 V = Air Cal Range.

4–20 mA concentration: Current increases with increasing oxygen concentration, from 4 mA at 0 oxygen content to 20 mA at full scale oxygen content. (Full scale = 100 % of programmed range.)

Alarm Relays: The three alarm-circuit connectors are screw terminals for making connections to internal alarm relay contacts. There is one set of contacts for each type of alarm. Contacts are Form C, with normally open and normally closed contact connections capable of switching up to 0.5 ampere at 125 V ac into a resistive load.

The alarm relay circuits are designed for failsafe operation, meaning the relays are energized during normal operation. If power fails the relays de-energize (alarms activated).

The contact connections are indicated diagrammatically on the rear panel as Normally Closed, Common, and Normally Open. Figure 3-2 explains how these act in failsafe operation.

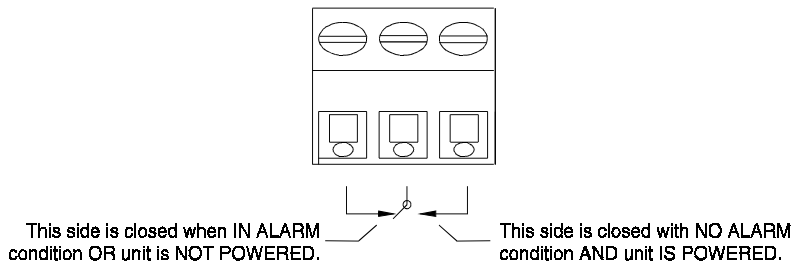

Figure 3-2: Contact ID for FAILSAFE Relay Operation

The specific descriptions for each type of alarm are as follows:

- HI Alarm** Configured as high alarm (actuates when concentration is above threshold). Can be set anywhere within the full range of the analyzer (0-9,999 ppm), but must be set ABOVE the threshold set for the LO Alarm.
- LO Alarm** Configured as low alarm (actuates when concentration is below threshold). Can be set anywhere within the full range of the analyzer (0-9,999 ppm), but must be set BELOW the threshold set for the HI Alarm.
- Sensor Fail** Actuates when the output of the Micro-Fuel Cell sensor falls below the acceptable level.

RS-232 Port: The digital signal output is a standard RS-232 serial communications port used to connect the analyzer to a modem or other digital device. Only the output mode is implemented in this instrument. The data is oxygen concentration and range information in serial digital form.

The RS-232 protocol allows some flexibility in implementation in the choice of values for certain parameters. Table 3-1 lists the RS-232 values required by the 3190 implementation.

Table 3-1: Required RS-232 Options

Parameter	Setting
Baud	2400
Byte	8 bits
Parity	none
Stop Bits	1
Message Rate	2 per second

External Probe: The receptacle for the analysis unit cable is located in the lower left-hand corner of the rear panel. The 6-pin Mini-Fit™ connector

is keyed to fit only one way into the receptacle. Do not force it in. The other end of the cable is made of four separate wires. These should be connected to the terminal strip on the analysis unit as follows:

Red:	#1	
Black:	#2	
Green:	#3	} The green and white connectors can be interchanged, but be consistent.
White:	#4	

Refer to the Final Assembly, Dwg. C-64641.

3.4 Gas Connections



Gas connection instructions depend on the specific External Probe used and any special requirements of the process being monitored.

The standard Model 3190 External Probe has inlet and outlet fixtures only. Calibration gasses must be tee'd into the sample inlet through appropriate valves. ¼ inch tube fittings are used. For metric installations, ¼ inch to 6 mm adapters are supplied.

In general, sample flow and pressure must not create significant backpressure past the sensor. For the standard probe, 2 scfh is the nominal recommended flowrate.

The pressure required will depend on the sampling system. When venting into a constant pressure, such as the atmosphere, controlling input pressure is simple. If you are venting into a system of varying pressure, then some form of pressure regulation is required.

3.5 Installation Checklist

Before connecting the instrument to the power source and turning it on, make sure you have:

- Correctly installed the Sample and Exhaust gas lines
- Opened the isolation valves
- Checked for leaks
- Set the sample pressure to 5–10 psig, nominal

Once the above checks have been made, you can connect to the power source. The instrument is now ready for operation.

Operation

4.1 Introduction

Once the analyzer has been mounted, the gas lines connected and the electrical connections made, the Analyzer can be configured for your application. This involves setting the system parameters:

- Defining the user selectable analysis ranges.
- Setting alarm setpoints.
- Calibrating the instrument.

All of these functions are performed via the front panel controls, shown in Figure 4-1.

Analyzing for the trace oxygen level in the gas passing through the cell block is the default mode of operation. As long as no front panel buttons are being pressed the Analyzer is analyzing.

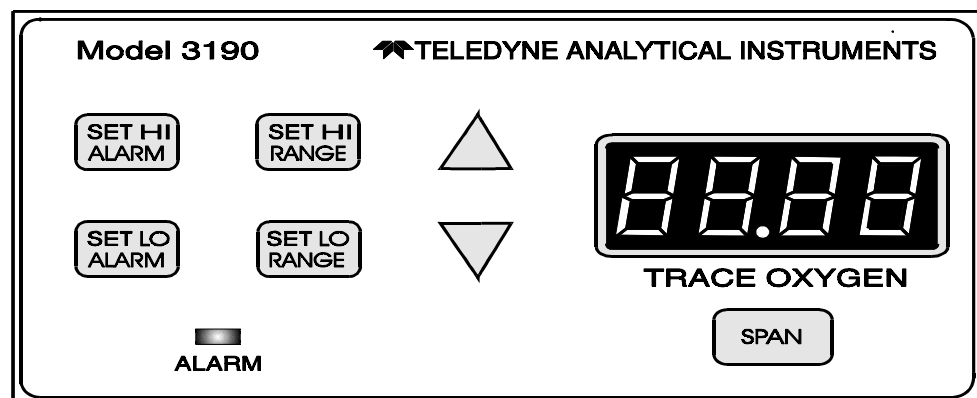

Figure 4-1: Front Panel Controls and Indicators

4.2 Using the Function and Data Entry

Buttons

When no buttons on the Analyzer are being pressed, the instrument is in the Analyze mode. It is monitoring the amount of oxygen in the sample gas that is flowing through the Remote Probe.

When one of the Function Buttons is being pressed, the Analyzer is in the Setup mode or the Calibration mode.

The 4 Setup Mode buttons on the analyzer are:

- *SET HI ALARM*
- *SET LO ALARM*
- *SET HI RANGE*
- *SET LO RANGE*

The Calibration Mode button is:

- *SPAN*

The Data Entry buttons (Δ and ∇) increment the values displayed on the TRACE OXYGEN meter while one of the Function buttons is being held down.

- Δ : Increments the displayed value upwards.
- ∇ : Increments the displayed value downwards.

Any of the functions can be selected at any time by holding down the appropriate button.

Each function will be described in the following sections. Although the operator can use any function at any time, the order chosen in this manual is appropriate for an initial setup.

4.3 Setting the Analysis Ranges

The two user definable analysis ranges are both capable of being adjusted for from 0-10 ppm to 0-9,999 ppm oxygen concentration.

Whatever values are selected, the analyzer automatically switches from the LO range to the HI range when the oxygen concentration reaches the LO range fullscale value, and it switches back to the LO range when the oxygen concentration falls below the LO range fullscale value

Note: For proper operation, the HI Range setpoint should be set at a higher concentration than the LO Range setpoint.

4.3.1 HI Range

Setting the HI Range fullscale value defines the LEAST sensitive analysis range to be used. To set the HI Range:

1. Press the SET HI RANGE Function button once.
2. Immediately (within 5 seconds) press either the Δ or ∇ button to raise or lower the displayed value, as required, until the display reads the desired fullscale concentration.

4.3.2 LO Range

Setting the LO Range fullscale value defines the MOST sensitive range to be used. To set the LO Range:

1. Press the SET LO RANGE Function button once.
2. Immediately (within 5 seconds) press either the Δ or ∇ button to raise or lower the displayed value, as required, until the display reads the desired fullscale concentration.

4.3.3 Settle Mode

The Model 3190 has two programmable ranges as discussed previous. Occasionally, to maximize accuracy the microprocessor must make certain adjustments to the gain of the amplifier which converts the sensor current into a voltage. When these adjustments are being made, the outputs of the analyzer are frozen and the LED will flash "SetL". This condition will persist for approximately 35 seconds and then normal operation will resume.

4.4 Setting the Alarm Setpoints

The alarm setpoints can be adjusted over the full range of the analyzer (0-9,999 ppm oxygen content). The setpoint values are expressed in ppm only.

Note: For proper operation, the HI Alarm setpoint should be set at a higher concentration than the LO Alarm setpoint.

4.4.1 HI Alarm

Setting the HI Alarm sets the value ABOVE which the HI Alarm will activate. To Set the HI Alarm:

1. Press the SET HI ALARM Function button once.

2. Within 5 seconds, press either the Δ or ∇ button to raise or lower the displayed value, as required, until the display reads the desired concentration.

4.4.2 LO Alarm

Setting the LO Alarm sets the value BELOW which the LO alarm will activate. To set the LO Alarm:

1. Press the SET LO ALARM Function button once.
2. Within 5 seconds, press either the Δ or ∇ button to raise or lower the displayed value, as required, until the display reads the desired concentration.

4.4.3 Sensor Fail Alarm

The SENSOR FAIL alarm triggers if, during calibration, the raw cell output for the given oxygen level is too low. (See *Calibration Characteristics* in Chapter 2.) Should this alarm trigger, The ALARM indicator below the SET function buttons will start blinking. Replace the cell before proceeding.

4.5 Selecting a Fixed Range or Autoranging

The Model 3190 can operate in fixed high, fixed low, or autoranging mode. To change modes:

1. Press and then release the SET HI RANGE and the SET LO RANGE buttons simultaneously.
2. Within 5 seconds, press either the Δ or ∇ button until Auto, Lo, or Hi displays on the LCD, as desired.

After about three seconds, the analyzer resumes monitoring in the selected range mode.

NOTE: If the concentration exceeds 9,999 ppm oxygen, the analyzer will automatically switch to the Calibration Range, EVEN THOUGH INSTRUMENT IS IN THE FIXED RANGE MODE.

4.6 Calibration

Preliminary—If not already done: Power up the Analyzer and allow the LED reading to stabilize. Set the Alarm setpoints and the fullscale ranges to the desired values.

Procedure:

1. Expose the sensor to ambient air or instrument grade air (20.9 % oxygen). Allow time for the sampling system to purge and the analyzer to achieve equilibrium.

Note: If the analyzer output goes above the high alarm setpoint or below the low alarm setpoint, the front panel ALARM Indicator, beneath the SET Function buttons, will blink. When the SPAN key is pressed to enter SPAN mode, Alarm indicator stops blinking.

2. Press the SPAN button once.
3. Within 5 seconds press either the Δ or ∇ button until the display is stable and reads 20.9 %.

The unit is now calibrated.

Note: If you use a span gas other than air, do not span in the 0-10 ppm range. Calibration at this level is not dependable.

Note: If you use a span gas other than air, and the span gas oxygen concentration is less than 10,000 ppm, the analyzer could take up to 65 seconds to settle. The lag is caused by a digital filter that is active only below 10,000 ppm (1%) oxygen.

If the output of the sensor as measured by the 3190 outside of the expected range due either to:

- a) Bad electrical connection between the unit and the sensor,
- b) Improperly analyzed or entered calibration gas value,
- c) Electronics failure

The unit will not accept the calibration attempted and flash 5000 on the LED display unit a valid calibration has been performed.

4.7 Displaying Percent & PPM on the LED Display

The analyzer displays the concentration in percent whenever the reading is over 9999 ppm. When the reading changes to percent, the LED display will alternate between flashing "PC" and the oxygen concentration. On the other hand, if the instrument is displaying ppm, only the concentration reading will be shown.

4.8 “SetL” mode in the LED display

When you turn on the unit, it displays “8.8.8.8” for a couple of seconds. This is to have an inspection that all segments of the display are all right. After the first two seconds, the LED display will show “SetL” and alternate with a countdown starting at 34.0. This countdown is to let the electronics settle and do a zero calibration of the electronics. Flowing “zero” gas or a sensor is **not** needed for this instrument adjustment. It is only an electronic zero calibration. The sensor is automatically disconnected by the 3190 hardware during this mode. As soon as the countdown reaches 0.00, the analyzer will go back to the normal mode of operation and the sensor is reconnected.

When the concentration rises above a point between 2000 to 3000 ppm (it changes from sensor to sensor) there are a few seconds where the display freezes. This is due to an automatic gain change to low gain. When the concentration drops and crosses a point between 3000 and 1500 ppm (it changes from sensor to sensor) the display will show “SetL” and alternate with a countdown of 30 seconds. This is due to an automatic gain change to high gain. It takes longer for the electronics to settle when switching to the high gain than when switching to low gain, that is the reason why the countdown only appears when the sensor reading is going down and not up.

Maintenance

Overvoltage Category II

Aside from normal cleaning and checking for leaks, the Model 3190 should not require any maintenance beyond replacement of expended Micro-Fuel Cells, and perhaps a blown fuse. Routine maintenance includes occasional recalibration, as described in chapter 4, *Operation*.

5.1 Replacing the Fuse

5.1.1 AC Powered Units

When a fuse blows, check first to determine the cause, then replace the fuse using the following procedure:

1. Disconnect the AC power and place the power switch located on the rear panel in the O position. Remove the power cord from the receptacle.
2. The fuse receptacle is located in the power cord receptacle assembly in the upper left-hand corner of the rear panel. See Figure 5-1.

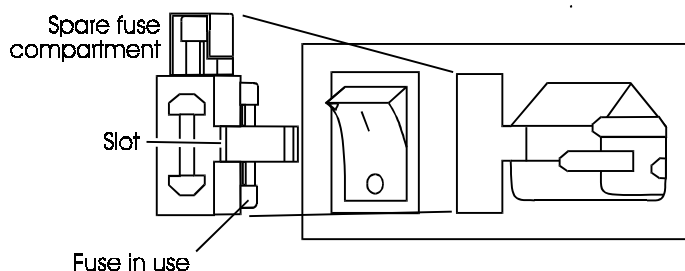

Figure 5-1: AC Fuse Replacement

3. Insert a small flat-blade screwdriver into the slot in the receptacle wall nearest the fuse and gently pry open the fuse receptacle. The fuse holder will slide out. The fuse in use is visible in the clip. To

open the spare fuse compartment, push on one end until it slides out.

4. Remove the blown fuse and replace it with a 5×20 mm 0.5 A, 250 VAC, IEC time lag (T) fuse (P/N F1128) for AC units.
5. Replace the fuse holder into its receptacle, pushing in firmly until it clicks.

5.1.2 DC Powered Units

In units with DC power, the fuse is located on the rear panel above the ON/OFF switch.

1. Open the fuse holder by unscrewing and removing the cap marked FUSE.
2. The fuse is located inside the receptacle, not inside the cap. Both terminals are on the same end of the fuse. Pull straight out without twisting to remove the old fuse from the receptacle, and replace it with a 0.5 A, 125 V dc, very quick acting (FF) microfuse (P/N F51).
3. Replace the cap by screwing it back into the receptacle.

5.2 Sensor Installation or Replacement

5.2.1 When to Replace a Sensor

There are several symptoms that may indicate sensor weakness other than the Sensor Failure Alarm.

- Cell failure in the 3190 is usually characterized very slow response to changes in oxygen levels below 100 ppm. This can cause errors in span calibration, since the sensor may not have time to settle properly.
- If large adjustments are required to calibrate the instrument, or calibration cannot be achieved within the range of the ΔV buttons, the cell may need replacing.
- If the front panel Trace Oxygen Meter displays “00.0” when the unit is plugged in, and the power switch is in the ON position, CHECK to make sure the sensor is connected. If it is, replace the sensor.

CAUTION: *Read the section Cell Warranty Conditions, below, before replacing the cell.*

CAUTION: *After replacing the Micro-Fuel Cell, the analyzer must be recalibrated. See Calibration in chapter 4.*

5.2.2 Ordering and Handling of Spare Sensors

To have a replacement cell available when it is needed, TAI recommends that one spare cell be purchased when the current cell's warranty period is approximately two thirds over.

CAUTION: *Do not stockpile cells. The warranty period starts on the day of shipment. For best results, do not order a new spare cell to soon.*

The spare cell should be carefully stored in an area that is not subject to large variations in ambient temperature (75 °F nominal), and in such a way as to eliminate the possibility of incurring damage.

CAUTION: *Do not disturb the integrity of the cell package until the cell is to actually be used. If the cell package is punctured and air is permitted to enter, cell-life will be compromised.*



WARNING: *THE SENSOR USED IN THE MODEL 3190 CONTAINS AN ELECTROLYTE WHICH INCLUDES SUBSTANCES THAT ARE EXTREMELY HARMFUL IF TOUCHED, SWALLOWED, OR INHALED. AVOID CONTACT WITH ANY FLUID OR POWDER IN OR AROUND THE UNIT. WHAT MAY APPEAR TO BE PLAIN WATER COULD CONTAIN ONE OF THESE TOXIC SUBSTANCES. IN CASE OF EYE CONTACT, IMMEDIATELY FLUSH EYES WITH WATER FOR AT LEAST 15 MINUTES. CALL A PHYSICIAN. (SEE APPENDIX, Material Safety Data Sheet—MSDS).*

5.2.3 Removing the Micro-Fuel Cell

Refer to Figure 5-2 for an exploded view of the cell block and cell. To remove a spent or damaged Micro-Fuel Cell:

1. **Disconnect the Power Source at the Control Unit.**
2. Disconnect the connector from the cell block if possible.

3. Unscrew the cell-retainer cap from the cell block by turning it counterclockwise until it is free.

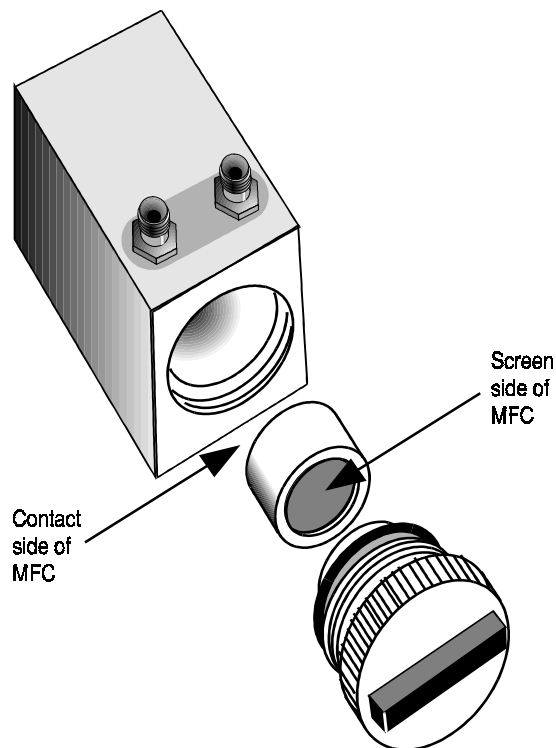

Figure 5-2: Exploded View of MFC and Cell Block

4. Slowly withdraw the cap from the block. *The cell should come out with the cap.*
5. Carefully pull the cell off of the cap. ***DO NOT TOUCH THE SCREENED END OF THE CELL OR ANY FLUID THAT MAY BE LEAKING FROM IT.***
6. Dispose of the cell in a safe manner, in accordance with all applicable ENVIRONMENTAL AND SAFETY laws.

5.2.4 Installing a Micro-Fuel Cell

To install a new Micro-Fuel Cell:

CAUTION: *Do not scratch, puncture, or otherwise damage the sensing membrane of the Micro-Fuel Cell. If the membrane is damaged, the cell must be replaced.*

1. **Disconnect the Power Source from the Control Unit.**
2. Remove the new Micro-Fuel Cell from its protective bag.
3. Examine the O-ring at the base of the threaded portion of the cell-retainer cap, and replace it if it is worn or damaged.
3. Replace the cell on the end of cell-retainer cap, which is designed to fit snugly into the rim on the screen side of the cell.
4. Careful insert the cap and cell into the block, and screw the cap clockwise into the cell block until it is held firmly in the cell.
5. Reconnect the cell block electrical connector plug.

5.2.5 Cell Warranty Conditions

The Class A-2C, B-2C or Z-2C Micro-Fuel cell is used in the Model 3190. These cells are warranted for 6 months, with an expected life of 8 months from the date of shipment (under specified operating conditions—see Appendix). Note any Addenda attached to the front of this manual for special information applying to your instrument.

Note that the warranty period begins on the date of shipment. The customer should stock only one spare cell per instrument at a time. Do not attempt to stockpile spare cells.

If a cell was working satisfactorily, but ceases to function before the warranty period expires, the customer will receive credit toward the purchase of a new cell.

If you have a warranty claim, you must return the cell in question to the factory for evaluation. If it is determined that failure is due to faulty workmanship or material, the cell will be replaced at no cost to you.

Note: Evidence of damage due to tampering or mishandling will render the cell warranty null and void.



Appendix

A.1 Specifications

Overvoltage Category II

Ranges:	Two user selectable ranges can be set between 0-10 ppm and 0-9,999 ppm oxygen. Default ranges are 0-100 ppm and 0-1,000 ppm oxygen, and a 0-25 % (nominal) Air Calibration Range.
Signal Output:	Voltage: 0–10 V dc, negative ground Current: 4-20 mA, negative ground
Range ID:	0-10 V dc.
Display:	Light emitting diode (LED) display.
Alarms:	One high alarm relay, adjustable; one low alarm relay, adjustable; one sensor failure relay. (All are failsafe.)
System Operating Temp:	0-50 °C
Accuracy:	±2 % of full scale at constant temperature ±5 % of full scale through operating temperature range (At 100 ppm and higher user defined ranges) once temperature equilibrium is reached. ±1 ppm for 10 ppm range under above conditions.
Response Time:	90 % in less than 65 seconds at 25 °C (68 °F).
System Power Requirement:	AC (100 to 240 V ac, 47/440 Hz), or DC (10-36 V dc); user specified.
System Enclosure:	<i>Panel Mount:</i> 2.81" H × 6.0" W × 2.87" D (71.4 mm × 152.4 mm × 72.9 mm). <i>Face Plate:</i> 3.75" H × 7.0" W

(95.3 mm H × 177.8 mm W). Faceplate rated to NEMA-4.

Sensor Type: Class A-2C, B-2C, and Z-2C
Analysis Unit: 4.0" H × 6.0" W × 2.5" D
 (101.6 mm × 152.4 mm × 63.5 mm)

A.2 Spare Parts List

QTY	P/N	DESCRIPTION
1	C-65220-A	PC Board, Main
1	C-64586	PC Board, Power Supply
1*	C-6689-B-2C	Micro-Fuel Cell, class B-2C
1*	C-6689-Z-2C	Micro-Fuel Cell, class Z-2C
2	F-1130	Fuse (AC), ½A, 250 VAC, IEC Type T, 5 x 20mm
1	F-51	Fuse (DC), ½A, 125 VDC, Micro-Fuse
1	A-64678A	Probe to Analyzer Cable, 6 ft
1*	C-6689-A-2C	Micro-Fuel Cell, class A-2C

* Order one type only: A-2C, B-2C, or Z-2C. See Specific Model Information in front of this manual for cell class supplied with your analyzer.

A minimum charge is applicable to spare parts orders.

IMPORTANT: Orders for replacement parts should include the part number and the model and serial number of the system for which the parts are intended.

Send orders to:

Teledyne Analytical Instruments
 16830 Chestnut Street
 City of Industry, CA 91749-1580

Telephone: (626) 934-1500

Web Site: www.teledyne-ai.com

Fax: (626) 961-2538, (626) 934-1651

Technical Support: (626) 534-1673

Web: www.teledyne-ai.com

or your local representative.

A.3 Drawing List

C-64772	Outline diagram
C-64641	Final Assembly (and interconnection diagram)
D-65666	Control Unit Assembly
B-65992	Analysis unit outline

A.4 Miscellaneous

The symbol: ~ is used on the rear panel of the model 3190 to signify volts alternating current (V ac).

NOTE: The MSDS on this material is available upon request through the Teledyne Environmental, Health and Safety Coordinator. Contact at (626) 934-1592

